



Energy Theme; Grant Agreement No 226369

Partners: Iberdrola Distribución, Actaris SAS, ADD, Cesi Ricerca, Electricité de France (EDF), Elster, Endesa, Netbeheer Netherlands, Unika, Kema, Landis+Gyr, ZIV Medida

Responsible: Kema

Public

Circulation: **Confidential**

Restricted

Title: Definition of Test Procedures

Version: 1.0

Page: 1 / 110

D 4.1

DEFINITION OF TEST PROCEDURES

DUE DELIVERY DATE:

ACTUAL DELIVERY DATE:

© Copyright 2009 The OPEN meter Consortium

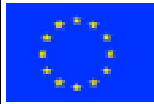

Energy Theme; Grant Agreement No 226369

Title: Definition of Test procedures

Version: 0.4

Page: 2 / 110

Document History

Vers.	Issue Date	Content and changes
0.1	30.03.10	Initial draft
0.2	26.04.10	2 nd draft
0.3	17.05.10	3rd draft
0.4	04.06.10	4rd draft
1.0	02.07.10	Technical Committee revised version

Document Authors

Partners	Contributors
Kema	Maurice Adriaensen, Elena Henríquez
uSysCom	Laura Marrón
EDF	Gaizka Alberdi, Aline Pajot, Regis Sebastien
Landis + Gyr	Guillaume Timmins, Michel Michou
Iberdrola	Iñigo Larumbe
DLMS UA	Gyozo Kmethy
Endesa	Amador Gómez, Carmelo Rodríguez, Robert Denda



OPEN meter

Open Public Extended Network metering



Work Package: WP4

Type of document: Deliverable 4.1

Date: 04/06/2010

Energy Theme; Grant Agreement No 226369

Title: Definition of Test procedures

Version: 0.4

Page: 3 / 110

Document Approvers

Partners	Approvers
Landis + Gyr	Thomas Schaub
Endesa	Robert Denda



TABLE OF CONTENTS

1	INTRODUCTION	6
2	OBJECTIVES AND SCOPE	6
2.1	DEFINITIONS	7
2.2	PRESENTATION OF TEST CASES	8
3	PLC TEST CASES	9
3.1	OBJECTIVES AND SCOPE	9
3.2	REFERENCE STANDARDS	11
3.3	SYSTEM UNDER TEST (SUT) USER INTERFACE REQUIREMENTS	13
3.4	PRESENTATION OF TEST CASES	14
3.4.2	Data - Link layer tests	41
3.4.3	Functional use cases	53
4	DLMS FUNCTIONAL TEST CASES	62
4.1	INTRODUCTION	62
4.2	PRESENTATION OF TEST CASES	62
4.2.1	Provide periodic meter readings (Use case 1)	62
4.2.2	Provide on demand meter reads (Use case 2)	66
4.2.3	Provide load profile (use case 4)	68
4.2.4	Provide power quality information information (Use case 6)	69
4.2.5	Provide interruption information (Use case 7)	72
4.2.6	Provide tamper history (tamper detection) (Use case 8)	75
4.2.7	(Dis)connect Electricity (Use case 9)	77
4.2.8	Apply Threshold (electricity) (Use case 10)	81
4.2.9	Shift tariff times electricity (use cases 14)	86
4.2.10	Synchronize time E-equipment (Electricity-equipment) (Use case 15)	87
4.2.11	Firmware upgrade (Business use cases)	89
	APPENDIX A – CHECK LIST OF REQUERIMENTS.	94
	APPENDIX B.- DLMS/COSEM CONFORMANCE TESTING	99
	INTRODUCTION	99
	THE DLMS/COSEM CONFORMANCE TESTING PROCESS	99
	MAIN FEATURES OF DLMS/COSEM CONFORMANCE TESTING	101
	SCOPE OF TESTING	101
	DEVICE TESTING	101
	STRUCTURE OF THE CONFORMANCE TEST PLANS	101
	ABSTRACT TEST CASES	103
	TEST OUTCOMES AND VERDICTS	103
	CONFORMANCE TEST PLAN FOR THE DATA LINK LAYER USING HDLC PROTOCOL	104
	CONFORMANCE TEST PLAN FOR THE COSEM APPLICATION LAYER	104
	CONFORMANCE TEST PLAN FOR THE COSEM INTERFACE OBJECTS	105
	THE DLMS/COSEM CONFORMANCE TEST TOOL	106
	THE CONFORMANCE TEST REPORT, THE CONFORMANCE LOG AND THE LINE TRAFFIC	106
	THE CONFORMANCE ASSESSMENT PROCESS	107
	THE CERTIFICATION	107



OPEN meter

Open Public Extended Network metering



Work Package: WP4

Type of document: Deliverable 4.1

Date: 04/06/2010

Energy Theme; Grant Agreement No 226369

Title: Definition of Test procedures

Version: 0.4

Page: 5 / 110



1 Introduction

The definition of test approaches and test procedures make up an important part of the OPEN meter project.

The DoW of WP 4 sets the task as follows:

WP4 (Testing) will define the test approach and test procedures necessary for validating the solutions proposed in WP3.

Development of the first set of prototypes for testing, definition of tests and test facilities, execution of compliance tests, laboratory testing and interoperability field testing will be some of the activities planned to ensure that the proposed solution is feasible and adequate.

The objectives of this work package are:

- To be able to test prototypes of the implementations of communication standards in an early phase.
- To get insight in the compliance of products to the standards that are selected and/or defined in WP3.
- To get insight in the interoperability of components of the OPEN meter Advanced Metering Infrastructure.
- To make the validation of the proposed OPEN meter system by testing the solution proposed in laboratory tests and field trials.

2 Objectives and scope

The objective of this deliverable is the definition of the test procedures and test cases in order to check that the field devices are compliant with Open Meter requirements and to assure the interoperability of the field devices.

The document is focused in the first technologies and protocols selected by WP3 as *easy choices* for Open Meter:

For PLC technologies: S-FSK, PRIME.

For protocols: DLMS/COSEM.

It is expected that in Q4 2010 a new version of this document can be released. This new version will include additional technologies, such as G3 and MORE and protocols and improvements of the current test cases, based on experience acquired during laboratory and field testing.



Energy Theme; Grant Agreement No 226369

Title: Definition of Test procedures

Version: 0.4

Page: 7 / 110

The document covers conformance, performance and functional testing for meter for interfaces defined in WP1: MI1/CI1 and MI2/SI2

In chapter 3 PLC conformance and performance test cases are described.

In chapter 4 functional test cases to check compliance with the Open Meter functional and performance requirements specified in deliverable D1.1. are described.

Conformance testing for DLMS/COSEM has been specified by the DLMS UA. This is described in Appendix B.

2.1 Definitions

- Functional testing: checking the system requirements according D1.1 section 3.1 and section 4.1
- Performance testing: checking the performance requirements according D1.1 section 4.1.4
- Interoperability testing: Testing if in a system devices from different manufacturers can operate together without problems. It should be possible to replace a device by a device of another manufacturer without causing communication problems.
- Conformance testing : Conformance testing is the act of determining to what extent a single implementation conforms to the individual requirements of its base standard

Conformance and interoperability testing are both important and useful approaches to the testing of standardized protocol implementations although it is unlikely that one will ever fully replace the other. Conformance testing is able to show that a particular implementation complies with all of the protocol requirements specified in the associated base standard. However, it is difficult for such testing to be able to prove that the implementation will interoperate with similar implementations in other products. On the other hand, interoperability testing can clearly demonstrate that two implementations will cooperate to provide the specified end-to-end functions but cannot easily prove that either of them conforms to the detailed requirements of the protocol specification.

Conformance testing does not prove end-to-end functionality/interoperability between two communicating systems. It does not test a complete product but only certain parts. Items passing conformance testing may still not interoperate. This is often a base specification problem rather than a test specification problem. The production of conformance test specifications and tools is an up-front, expensive undertaking; nevertheless all in all, experience has shown that conformance testing is an extremely cost-effective solution once the tests are available.

On the other hand, interoperability testing proves interoperability only between the devices in the System Under Test. It does not prove that a product that conforms to the specification. Interoperable products may still be non-conformant and still not function correctly. Interoperability tests do not explicitly cover unusual or received error behavior because there is no manner of forcing expected behavior. A successful interoperability test using devices A



and B and another using devices B and C do not guarantee that devices A and C will interoperate. Interoperability tests may not be repeatable for other than normally expected events. The test equipment for interoperability testing is usually less expensive than conformance testing equipment but the setting up of an interoperability test bed is not trivial. Interoperability test specification development is less expensive than conformance test specifications.

Thus, interoperability testing is not better than conformance testing and vice versa. The approaches are complementary and not mutually exclusive. Complex technologies, the cost of getting things wrong, and a renewed interest in branding and certification programs encourage a combined approach.

The difference between conformance testing and interoperability testing can be clearly illustrated with the two Figures following:

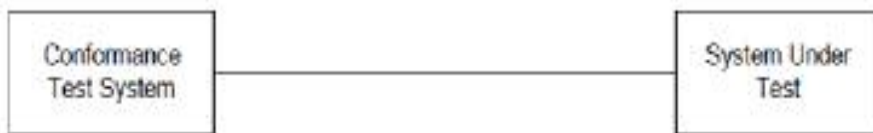

Figure 1 – Illustration of conformance testing



Figure 2 – Illustration of interoperability testing

Conformance testing allows verifying that the features implemented conform to the requirements of the standard. Interoperability testing allows verifying that different implementations support the same options and choices, where such options and choices are allowed by the standard.

2.2 Presentation of test cases

In this document the test cases are presented in tables. The table below presents the template for a test case; the explanation for the attributes in the table is given in brackets.

Test case ID	<i>UNIQUE IDENTIFIER FOR THE TEST CASES</i>	Use case	Use case that is being addressed by the test cases
Description	This is the general description of the test case. The description itself gives a general idea of what is required and its objective.		
Technology / Protocol	This attribute indicates which technology or protocol is being addressed by this test cases		
Test Environment	Laboratory <input type="checkbox"/>	Field (prototypes in parallel) <input type="checkbox"/>	Field (Substituted Meters) <input type="checkbox"/>



[type of environment where the tests are developed]							
Pre-conditions	Description of the environment and necessary configuration and set-up to be done before starting the tests.						
Steps	This section describes the different steps to perform in the test case.						
Requeriments	Requirement ID [This attribute indicates the requirement id according to D1.1]	Description [This is the general description of the requirement].			Category [This attribute describes if the requirement is minimum, advanced or optional]		
Fit criterion	This attribute provides insight on the criteria that will be used to verify if the test cases is passed.						
History	[Date the test case was accepted]	Origin	[Indicates the originator of the test case, e.g. Open meter.]	Inter face	[Interface that is being addressed test case]	Applicable	[Indicates the applicability of the test case, e.g. Electricity Meter/communication hub, Multi-utility meter, concentrator, etc.

3 PLC test cases

3.1 Objectives and scope

This document is a proposal for PLC laboratory tests and validation. It contains the main tests to pass in order to validate PLC prototypes.

PLC communication profile is based on a multilayer architecture referring to the OSI model. Taking this into account, the tests have been classified from a layered point of view.

This document contains for each test a brief description with constraints and test conditions.

In addition to these laboratory tests, functional field tests should be taken into consideration.

Referring to OSI model, three main functional tests sets can be considered:



Energy Theme; Grant Agreement No 226369

Title: Definition of Test procedures

Version: 0.4

Page: 10 /
110

1. **Physical layer tests:** The PHY layer defines the means of transmitting raw bits over a physical link connecting two modems. In this tests set the conformance to the CENELEC standards, the dynamic range and the robustness against noise are tested.
2. **Data Link layer tests:** The DL layer transfers data between adjacent network nodes. It provides the functional and procedural means to detect and correct errors that may occur in the PHY layer. The DL layer is normally divided in two sublayers, the MAC layer and the Convergence sublayer. This tests set will focus on the main functional features of DL layer, especially useful throughput, efficiency and robustness facing network topology changes or problems due to the physical medium
3. **Upper Layers tests:** The upper layers in these communication profiles link the application layer with the lower layers such as the Convergence sublayer. According to the metering application, COSEM objects can be tested.

Note: The DL layer and Upper layer tests are only possible if the products under test offer proper interfaces above which testing applications are provided.



3.2 Reference standards

The layers in the different PLC profiles are described below:

DLMS: The names of the layer shall be added.

IEC 62056-61&6-62: Data Model

IEC 62056-53 Application layer etc.

S-FSK Profile :

IEC 62056-61 & 62 COSEM data model
IEC 62056-53 COSEM application
IEC 61334-4-32 LLC
IEC 61334-5-1 PHY&MAC layer

PRIME Profile :

COSEM data model	COSEM data model
COSEM application layer	COSEM application layer
COSEM transport layer	
IETF TCP/UDP	IEC 61334-4-32 LLC layer
IPv4 CONVERGENCE SUBLAYER	IEC 61334-4-32 CONVERGENCE SUBLAYER
PRIME COMMON PART CONVERGENCE SUBLAYER	
PRIME MAC LAYER	
PRIME PHY LAYER	

EN 50065-1 : Signalling on low-voltage electrical installations in the frequency range 3 kHz to 148,5 kHz - Part 1: General requirements, frequency bands and electromagnetic disturbances

EN 50065-7 : Signalling on low-voltage electrical installations in the frequency range 3 kHz to 148,5 kHz - Part 7: Equipment impedance



Energy Theme; Grant Agreement No 226369

Title: Definition of Test procedures

Version: 0.4

Page: 12 /
110

IEC 62056-53 : Electricity metering – Data exchange for meter reading, tariff and load control – Part 53: COSEM application layer

IEC 62056-61 : Electricity metering – Data exchange for meter reading, tariff and load control – Part 61: Object identification system (OBIS)

IEC 62056-62 : Electricity metering – Data exchange for meter reading, tariff and load control – Part 62: Interface classes

IEC 62056-47 : Electricity metering – Data exchange for meter reading, tariff and load control – Part 47: COSEM transport layers for IPv4 networks

IEC 61334-5-1: Lower layer profiles – The spread frequency shift (S-FSK) profile

IEC 61334-4-32 : Data communication protocols – Data link layer – Logical link control (LLC)



3.3 System Under Test (SUT) user interface requirements

The product manufacturers have to provide an application permitting to manage their master and slave PLC communication devices:

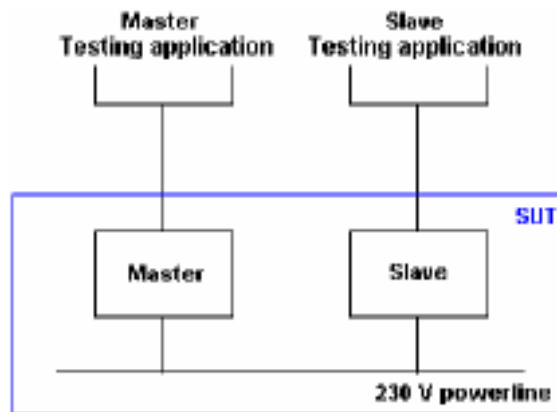

The requirements for testing applications for DL and Upper Layers described below are mandatory to properly perform DL and Upper layer tests.



3.4 Presentation of test cases

Presentation of test cases

1. PHY Layer
1. Conformance to EN 50065-1 standard
2. Dynamic range
3. Robustness against impulsive noise
4. Robustness against white noise
5. Robustness against sinusoidal noise
6. Robustness against frequency selective noise
7. Robustness against periodic disturbance test
8. Fast transients IEC61000-4-4
9. Transient immunity : Conducted disturbances immunity Test IEC61000-4-6
10. Transient immunity : Damped oscillatory waves IEC 61000-4-12
11. Crosstalk
12. Behaviour within a low impedance circuit
13. Coexistence testing
14. Phase detection

Test case ID	3.4.1.1		Type of test	Conformance			
Description	Verify the conformance to EN 50065-1 according to the method described in the standard						
Technology / Protocol	PLC Technologies						
Test Environment	Laboratory X	Field (prototypes in paralell) <input type="checkbox"/>	Field (Substituted Meters) <input type="checkbox"/>				
Pre-conditions	Testing configuration : Refer to the EN 50065-1 standard.						
Steps	As described in the EN 50065-1 standard.						
Requirements	OM-CR 3	When PLC is used, the minimum speed must be 2.4 kbps for a reliable communication	Minimum				
	OM-CR 4	A reliable faster PLC interface should be possible.	Optional				
Fit criterion	Indicate the results that state the conformance to EN 50065-1 standard						
History	April 2010	Origin	OPEN METER WP4.1	Interface	MI1-C11	Applicable	Electricity Meter/ concentrator



Test case ID	3.4.1.2		Type of test	performance
Description	The objective of this test is to measure the effect of attenuation on the PLC transmission.			
Technology / Protocol	PLC Technologies			
Test Environment	Laboratory X	Field (prototypes in paralell) <input type="checkbox"/>	Field (Substituted Meters) <input type="checkbox"/>	
Pre-conditions	<p>Testing configuration :</p>			
Steps	<p>Description of the test :</p> <p>While the master and the slave are communicating continuously, attenuation is gradually increased until the communication breaks (typical values for the variable attenuation are from 0 to 90 dB).</p> <p>Unidirectional communication between the master and the slave. It is possible through a sniffer to count the number of frames exchanged between the master and the slave. 1000 frames will be sent for statistics purposes for a given attenuation.</p> <p>This test has to be performed for all the modulation schemes, all the different speed and different payload sizes, according to what is available for the tested technology.</p> <p>NOTE 1: If there are some reasons to think that the communication performances are not the same in the way Master to slave than in the way Slave to Master, this test has to be passed twice</p> <ul style="list-style-type: none"> - Unidirectional communication from master to slave - Unidirectional communication from slave to master 			
Requirements	OM-CR 3	When PLC is used, the minimum speed must be 2.4 kbps for a reliable communication	Minimum	



Energy Theme; Grant Agreement No 226369

Title: Definition of Test procedures

Version: 0.4

Page: 16 / 110

	OM-CR 4	A reliable faster PLC interface should be possible.					Optional
	OM-GR19	System must be robust					Minimum
Fit criterion	For each configuration tested, fill in a table as the example given below the performances obtained:						
	Attenuation value (dB)		0 dB	30 dB	50 dB	70 dB	
	Frame error rate (frame length = xx bytes)		0%	0%	0%	19%	
	Bit error rate		0%	0%	0%	8%	
	NOTE: Accuracy in the communication break threshold has to be of 1 dB steps						
History	April 2010	Origin	OPEN METER WP4.1	Inter face	MI1-C11	Applicable	Electricity Meter/ concentrator

Test case ID	3.4.1.3		Type of test	performance
Description	This test tries to resolve which is the behavior of PLC technology in the presence of impulsive noise. This scenario tries to emulate some real-world problems which will be found in real deployments. The result of these test may show the robustness of PLC technology, and maybe allow their improvement if they are not frozen yet. This test takes into account a scenario where a sudden impulsive noise jams all the frequency band in such a way that it has far more power than PLC signals, making impossible the communication as long as the perturbation is present in the AC line. This case appears quite often in meter rooms, for instance when an elevator starts moving, the impulse start up of the motors creates a burst of low frequency noise.			
Technology / Protocol	PLC Technologies			
Test Environment	Laboratory X	Field (prototypes in paralell) <input type="checkbox"/>		Field (Substituted Meters) <input type="checkbox"/>
Pre-conditions	NOTE: It is important to respect exactly the schematics proposed below during the measurements and tests, and not to add any additional device, because this would change the impedance and therefore disturb the precision of the measurements. (NB: the schematics have been designed so that the impedance on the server side is always the same)			
	Testing configuration :			
	1/ Signal level measurement :			

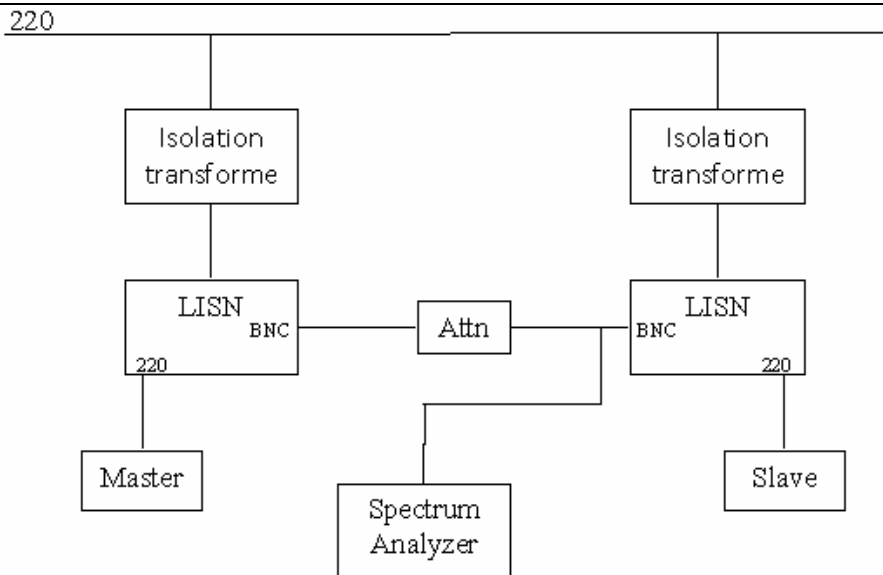

The Master must be set in continuous transmission mode (special continuous transmission mode, or normal transmission with no pause between frames). The measurement must be done in RMS, not with peak value, with a bandwidth exceeding the bandwidth of the transmitter.

$$S_0 = S_{meas} - 6dB$$

S_0 : signal level

S_{meas} : signal level measured with spectrum analyzer.

Attn : 20dB

Important warning regarding the IEC 61334-5-1 standard:

The IEC 61334-5-1 standard takes into account the energy received for a bit instead of the power received. This measurement method is not valid here because the signal level is not unlimited, but it must be below the maximum described in EN 50065-1 standard

2/ Error rate measurement with noise:



Energy Theme; Grant Agreement No 226369

Title: Definition of Test procedures

Version: 0.4

Page: 18 / 110

	<p>Attn: 20dB</p> <p>NOTE: The communication between the master and the slave has to be compulsorily unidirectional (and the other way around)</p>		
Steps	<p>Description of the test :</p> <p>By the means of a function generator, an impulsive noise is introduced in the network. This impulsive noise consists on a white noise signal, with a level well above the pilot carriers of PLC signal, with a certain period. The proposed levels are the following (to be agreed):</p> <ul style="list-style-type: none"> • 10us of noise blocking every 10msec. • 100us of noise blocking every 10msec. • 1msec of noise blocking every 10msec. <p>It is possible through a sniffer to count the number of frames exchanged between the master and the slave. 1000 frames will be sent for statistics purposes</p> <p>This test has to be performed for all the modulation schemes, with and without convolutional encoder, all the different speed and different payload sizes, according to what is available for the tested technology.</p> <p>NOTE 1: If there are some reasons to think that the communication performances are not the same in the way Master to slave than in the way Slave to Master, this test has to be passed twice</p> <ul style="list-style-type: none"> - Unidirectional communication from master to slave - Unidirectional communication from slave to master (with FG placed next to Master instead) 		
Requirements	OM-CR 3	When PLC is used, the minimum speed must be 2.4 kbps for a reliable communication	Minimum
	OM-CR 4	A reliable faster PLC interface should be possible.	Optional



Energy Theme; Grant Agreement No 226369

Title: Definition of Test procedures

Version: 0.4

Page: 19 / 110

	OM-GR19	System must be robust					Minimum																					
Fit criterion	<p>This test aims only at the PHY layer of PLC technology, and the underlying test procedure is to check whether a point-to-point PLC communication can be established and maintained in the presence of certain disturbances. The idea is to see whether the frames can be received correctly or not for the proposed test cases.</p> <p>For each configuration tested, fill in a table as the example given below the performances obtained:</p> <table border="1" style="margin-left: 40px;"> <tr> <td>Noise period (ms)</td> <td>0,01</td> <td>...</td> <td></td> <td></td> <td></td> <td></td> </tr> <tr> <td>Frame error rate (frame length = xx bytes)</td> <td>...</td> <td>...</td> <td></td> <td></td> <td></td> <td></td> </tr> <tr> <td>Bit error rate</td> <td></td> <td></td> <td></td> <td></td> <td></td> <td></td> </tr> </table>							Noise period (ms)	0,01	...					Frame error rate (frame length = xx bytes)					Bit error rate						
	Noise period (ms)	0,01	...																									
	Frame error rate (frame length = xx bytes)																									
Bit error rate																												
History	April 2010	Origin	OPEN METER WP4.1	Inter face	MI1-C11	Applicable	Electricity Meter/ concentrator																					

Test case ID	3.4.1.4	Type of test	performance
Description	<p>This test tries to resolve which is the behavior of PLC technology in the presence of wideband white noise. This scenario tries to emulate some real-world problems which will be found in real deployments. The result of these test may show the robustness of PLC technology, and maybe allow their improvement if they are not frozen yet. This test outlines the behavior of PLC technology in a low SNR scenarios, where noise power is evenly distributed in the band and PLC signal power is only some dB above the noise floor. This test represents the case of a long link in a rural areas, where high attenuation and low noise should be expected in the AC mains. As a result of this, the SNR shall be constant and small in value.</p> <div style="text-align: center;"> </div>		
Technology / Protocol	PLC Technologies		

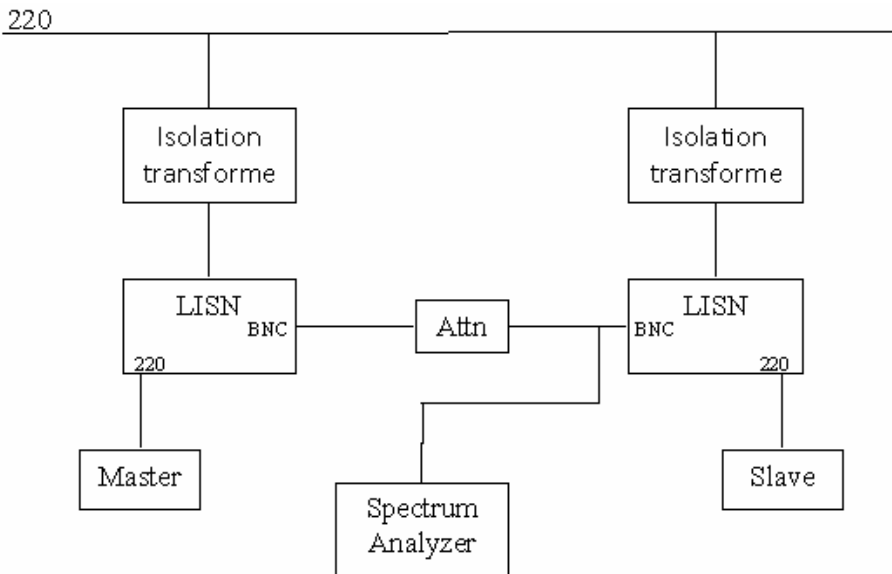

Test Environment	Laboratory X	Field (prototypes in parallel) <input type="checkbox"/>	Field (Substituted Meters) <input type="checkbox"/>
Pre-conditions	<p>NOTE: It is important to respect exactly the schematics proposed below during the measurements and tests, and not to add any additional device, because this would change the impedance and therefore disturb the precision of the measurements. (NB: the schematics have been designed so that the impedance on the server side is always the same)</p> <p>Testing configuration :</p> <p>1/ Signal level measurement :</p>  <p>The Master must be set in continuous transmission mode (special continuous transmission mode, or normal transmission with no pause between frames). The measurement must be done in RMS, not with peak value, with a bandwidth exceeding the bandwidth of the transmitter.</p> <p>$S_0 = S_{meas} - 6dB$ S_0 : signal level S_{meas} : signal level measured with spectrum analyzer. Attn : 20dB</p> <p>Important warning regarding the IEC 61334-5-1 standard:</p> <p>The IEC 61334-5-1 standard takes into account the energy received for a bit instead of the power received. This measurement method is not valid here because the signal level is not unlimited, but it must be below the maximum described in EN 50065-1 standard</p> <p>2/ Noise level measurement</p>		

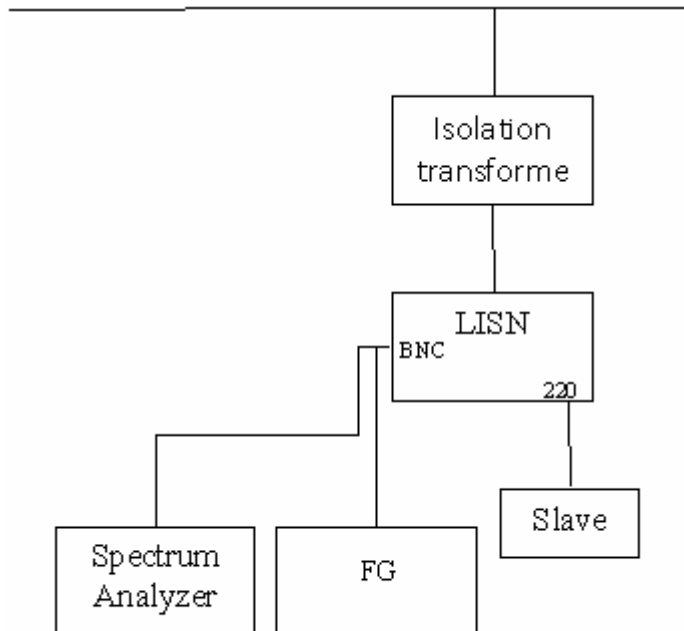

NOTE: The measurement must be done in RMS, not with peak value. We must take into account the bandwidth used by the spectrum analyzer to determine the noise level.

$$N_0 = N_{\text{meas}} - 10 \log (\text{Band}) - 6\text{dB}$$

N_0 : noise level

Band: bandwidth of the filter used with the spectrum analyzer

N_{meas} : noise level measured with spectrum analyzer.

3/ Error rate measurement with noise:



Energy Theme; Grant Agreement No 226369

Title: Definition of Test procedures

Version: 0.4

Page: 22 / 110

	<p style="text-align: center;">Attn: 20 dB</p>		
Steps	<p>Description of the test :</p> <p>By the means of a function generator, a white noise is introduced in the network.</p> <p>The following test list is proposed (to be agreed):</p> <ul style="list-style-type: none"> • Noise floor 10dB below the level of PLC carriers. • Noise floor 6dB below the level of PLC carriers. • Noise floor 3dB below the level of PLC carriers. <p>Unidirectional communication between the master and the slave. It is possible through a sniffer to count the number of frames exchanged between the master and the slave. 1000 frames will be sent for statistics purposes</p> <p>This test has to be performed for all the modulation schemes, with and without convolutional encoder, all the different speed and different payload sizes, according to what is available for the tested technology.</p> <p>NOTE 1: If there are some reasons to think that the communication performances are not the same in the way Master to slave than in the way Slave to Master, this test has to be passed twice</p> <ul style="list-style-type: none"> - Unidirectional communication from master to slave - Unidirectional communication from slave to master (with FG placed next to Master instead) 		
Requirements	OM-CR 3	When PLC is used, the minimum speed must be 2.4 kbps for a reliable communication	Minimum
	OM-CR 4	A reliable faster PLC interface should be possible.	Optional
	OM-GR19	System must be robust	Minimum



Energy Theme; Grant Agreement No 226369

Title: Definition of Test procedures

Version: 0.4

Page: 23 / 110

Fit criterion	<p>This test aims only at the PHY layer of PLC technology, and the underlying test procedure is to check whether a point-to-point PLC communication can be established and maintained in the presence of certain disturbances. The idea is to see whether the frames can be received correctly or not for the proposed test cases.</p> <p>SCENARIO 1: For each configuration tested, fill in a table as the example given below the performances obtained:</p> <table border="1"> <tr> <td>Noise amplitude (Vrms)</td> <td>0,1</td> <td>...</td> <td></td> <td></td> <td></td> <td></td> </tr> <tr> <td>Signal amplitude (Vrms)</td> <td>1</td> <td>...</td> <td></td> <td></td> <td></td> <td></td> </tr> <tr> <td>SNR (dB)</td> <td>20</td> <td>...</td> <td></td> <td></td> <td></td> <td></td> </tr> <tr> <td>Frame error rate (frame length = xx bytes)</td> <td>...</td> <td>...</td> <td></td> <td></td> <td></td> <td></td> </tr> <tr> <td>Bit error rate</td> <td></td> <td></td> <td></td> <td></td> <td></td> <td></td> </tr> </table>							Noise amplitude (Vrms)	0,1	...					Signal amplitude (Vrms)	1	...					SNR (dB)	20	...					Frame error rate (frame length = xx bytes)					Bit error rate						
	Noise amplitude (Vrms)	0,1	...																																							
Signal amplitude (Vrms)	1	...																																								
SNR (dB)	20	...																																								
Frame error rate (frame length = xx bytes)																																								
Bit error rate																																										
History	April 2010	Origin	OPEN METER WP4.1	Inter face	MI1-C11	Applicable	Electricity Meter/ concentrator																																			

Test case ID	3.4.1.5	Type of test	performance
Description	<p>This test tries to resolve which is the behavior of PLC technology in the presence of a narrow-band interfering signal. This scenario tries to emulate some real-world problems which will be found in real deployments. The result of these test may show the robustness of PLC technology, and maybe allow their improvement if they are not frozen yet.</p> <p>This narrow-band interfering signal may be located within the working frequency band (40-90KHz) or just outside the operating frequency band (10-40KHz, 90-150KHz). For instance, this kind of noise is generated by radio communication for military use (near 20kHz), or by some motor engine. The disturbance generated is in this case a sinusoidal signal.</p>		

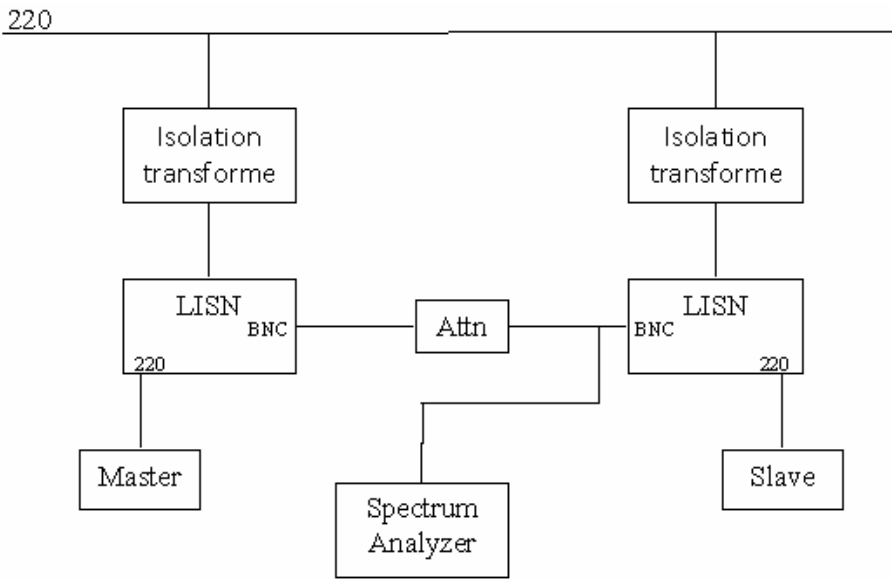

Technology / Protocol	PLC Technologies		
Test Environment	Laboratory X	Field (prototypes in parallel) <input type="checkbox"/>	Field (Substituted Meters) <input type="checkbox"/>
Pre-conditions	<p>NOTE: It is important to respect exactly the schematics proposed below during the measurements and tests, and not to add any additional device, because this would change the impedance and therefore disturb the precision of the measurements. (NB: the schematics have been designed so that the impedance on the server side is always the same)</p> <p>Testing configuration :</p> <p style="text-align: center;">1/ Signal level measurement :</p>  <p>The Master must be set in continuous transmission mode (special continuous transmission mode, or normal transmission with no pause between frames). The measurement must be done in RMS, not with peak value, with a bandwidth exceeding the bandwidth of the transmitter.</p> <p>$S_0 = S_{meas} - 6dB$ S_0 : signal level S_{meas} : signal level measured with spectrum analyzer. Attn: 20 dB</p> <p>Important warning regarding the IEC 61334-5-1 standard:</p> <p>The IEC 61334-5-1 standard takes into account the energy received for a bit instead of the power received. This measurement method is not valid here because the</p>		



signal level is not unlimited, but it must be below the maximum described in EN 50065-1 standard

2/ Noise measurements

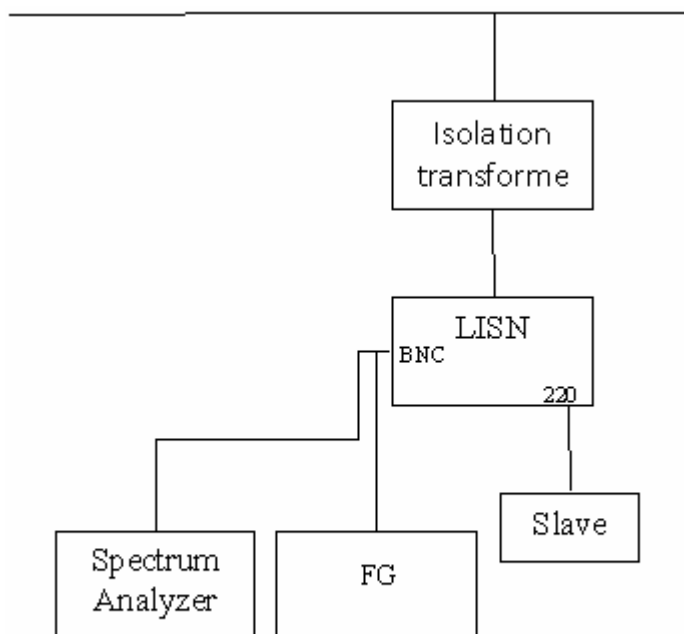

NOTE: The measurement must be done in RMS, not with peak value. We must take into account the bandwidth used by the spectrum analyzer to determine the noise level.

$$N_0 = N_{\text{meas}} - 6\text{dB}$$

N_0 : noise level

N_{meas} : noise level measured with spectrum analyzer.

Attn : 20dB

3/ Error rate measurement with noise:



	<p style="text-align: center;">Attn: 20 dB</p>		
Steps	<p>Description of the test :</p> <p>By the means of a function generator, a sinusoidal noise is introduced in the network.</p> <p>To perform the test of immunity in sinusoidal noise, proceed as follows:</p> <ul style="list-style-type: none"> - Set the noise level to achieve a SNR of -30dB (noise has to be superior in 30dB to the signal) (to be agreed) - Adjust the frequency of the noise signal - Send a series of frames with the Master - Register the number of frames and bits correctly received by the Slave - Repeat for other frequencies in order to scan the range 9-95kHz <p>The bit error rate must be $< 10^{-5}$.</p> <p>It is possible through a sniffer to count the number of frames exchanged between the master and the slave. In this case, 1000 frames will be sent for statistics purposes</p> <p>This test has to be performed for all the modulation schemes, all the different speed and different payload sizes, according to what is available for the tested technology.</p> <p>NOTE 1: If there are some reasons to think that the communication performances are not the same in the way Master to slave than in the way Slave to Master, this test has to be passed twice</p> <ul style="list-style-type: none"> - Unidirectional communication from master to slave - Unidirectional communication from slave to master (with FG placed next to Master instead) 		
Requirements	OM-CR 3	When PLC is used, the minimum speed must be 2.4 kbps for a reliable communication	Minimum
	OM-CR 4	A reliable faster PLC interface should be possible.	Optional
	OM-GR19	System must be robust	Minimum



Energy Theme; Grant Agreement No 226369

Title: Definition of Test procedures

Version: 0.4

Page: 27 / 110

Fit criterion	<p>This test aims only at the PHY layer of PLC technology, and the underlying test procedure is to check whether a point-to-point PLC communication can be established and maintained in the presence of certain disturbances. The idea is to see whether the frames can be received correctly or not for the proposed test cases.</p> <p>For each configuration tested, fill in a table as the example given below the performances obtained:</p>						
	Noise amplitude (Vrms)		0,1	...			
	Signal amplitude (Vrms)		1	...			
	SNR (dB)		20	...			
	frequency		60kHz	...			
	Frame error rate (frame length = xx bytes)				
	Bit error rate						
History	April 2010	Origin	OPEN METER WP4.1	Inter face	MI1-C11	Applicable	Electricity Meter/ concentrator

Test case ID	3.4.1.6	Type of test	Performance test
Description	<p>This test tries to resolve which is the behavior of PLC technology in the presence of a narrow-band interfering signal. This scenario tries to emulate some real-world problems which will be found in real deployments. The result of these test may show the robustness of PLC technology, and maybe allow their improvement if they are not frozen yet.</p> <p>This narrow-band interfering signal may be located within the working frequency band or just outside the operating frequency band For instance, an example of this type of noise is the conducted emission originated from switched mode power supplies. Some common working frequencies for these power supplies are 66KHz, 100KHz, 132KHz... The perturbances generated by these devices can be seen as a rather narrow carrier at the working frequency and all its harmonics.</p>		



Technology / Protocol	PLC Technologies		
Test Environment	Laboratory X	Field (prototypes in paralell) <input type="checkbox"/>	Field (Substituted Meters) <input type="checkbox"/>
Pre-conditions	<p>NOTE: It is important to respect exactly the schematics proposed below during the measurements and tests, and not to add any additional device, because this would change the impedance and therefore disturb the precision of the measurements. (NB: the schematics have been designed so that the impedance on the server side is always the same)</p> <p>Testing configuration :</p> <p style="text-align: center;">1/ Signal level measurement :</p> <p>The Master must be set in continuous transmission mode (special continuous</p>		



Energy Theme; Grant Agreement No 226369

Title: Definition of Test procedures

Version: 0.4

Page: 29 / 110

transmission mode, or normal transmission with no pause between frames). The measurement must be done in RMS, not with peak value, with a bandwidth exceeding the bandwidth of the transmitter.

$$S_0 = S_{meas} - 6dB$$

S_0 : signal level

S_{meas} : signal level measured with spectrum analyzer.

Attn: 20 dB

Important warning regarding the IEC 61334-5-1 standard:

The IEC 61334-5-1 standard takes into account the energy received for a bit instead of the power received. This measurement method is not valid here because the signal level is not unlimited, but it must be below the maximum described in EN 50065-1 standard

2/ Noise measurements

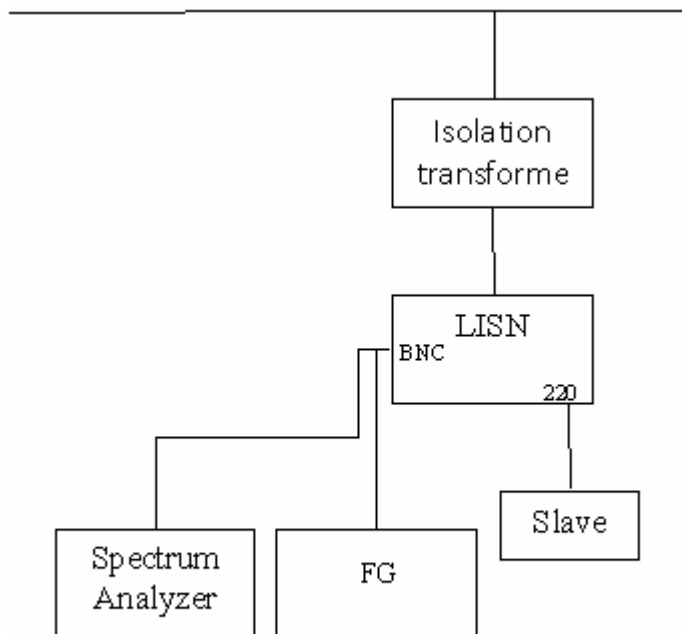

NOTE: The measurement must be done in RMS, not with peak value. The measurement must be done in RMS, not with peak value, with a bandwidth exceeding the bandwidth of the noise.

$$N_0 = N_{meas} - 6dB$$

N_0 : noise level

N_{meas} : noise level measured with spectrum analyzer.

Attn : 20dB

3/ Error rate measurement with noise:

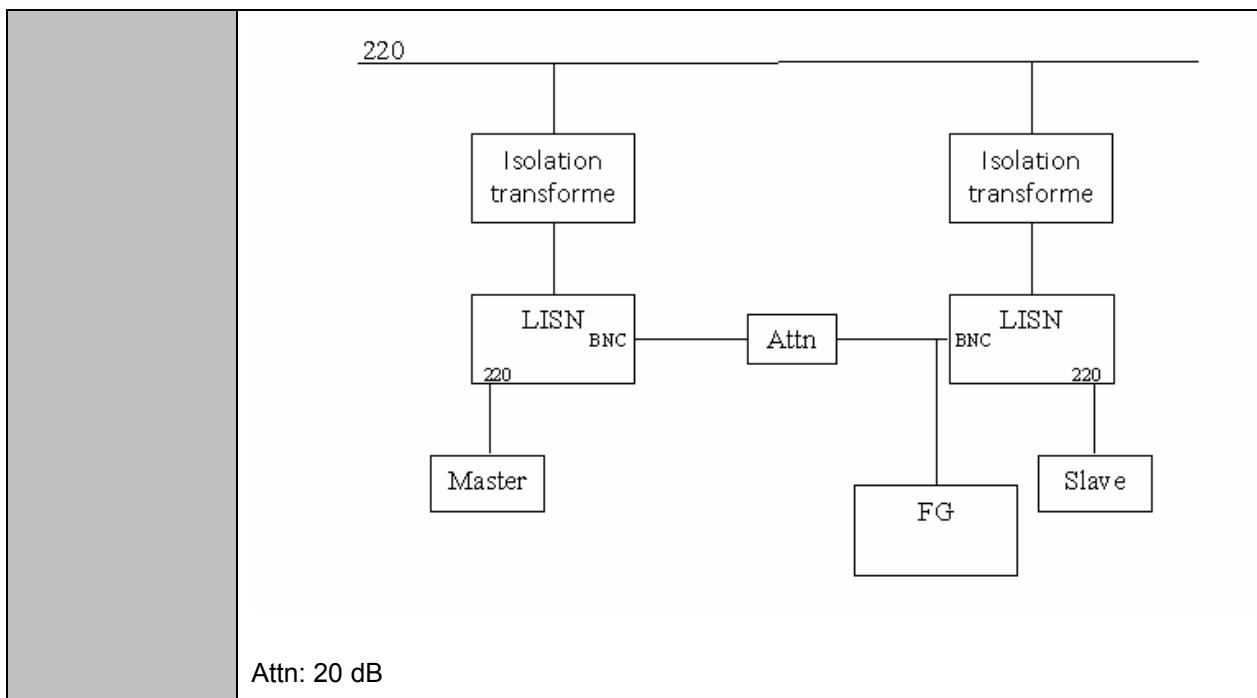

Attn: 20 dB

Steps

Description of the test :

By the means of a function generator, a frequency selective noise is introduced in the network.

Then the following test list is proposed (to be agreed):

- Carrier frequency 66KHz, bandwidth 1KHz.
- Carrier frequency 66KHz, bandwidth 5KHz.
- Carrier frequency 100KHz, bandwidth 1KHz.
- Carrier frequency 100KHz, bandwidth 5KHz.

For each test, the carrier frequency shall have the following amplitude values, compared with the level of PLC signal present on the wires: (to be agreed)

- Same level as PLCcarriers.
- Interference carrier 10dB above PLC carriers.
- Interference level 20dB above PLC carriers.

Unidirectional communication between the master and the slave. It is possible through a sniffer to count the number of frames exchanged between the master and the slave. In this case, 1000 frames will be sent for statistics purposes

This test has to be performed for all the modulation schemes, with and without convolutional encoder, all the different speed and different payload sizes, according to what is available for the tested technology.

NOTE 1: If there are some reasons to think that the communication performances are not the same in the way Master to slave than in the way Slave to Master, this test has to be passed twice:

- Unidirectional communication from master to slave
- Unidirectional communication from slave to master (with FG placed next to Master)



Energy Theme; Grant Agreement No 226369

Title: Definition of Test procedures

Version: 0.4

Page: 31 / 110

	instead)						
Requirements	OM-CR 3	When PLC is used, the minimum speed must be 2.4 kbps for a reliable communication				Minimum	
	OM-CR 4	A reliable faster PLC interface should be possible.				Optional	
	OM-GR19	System must be robust				Minimum	
Fit criterion	This test aims only at the PHY layer of PLC technology, and the underlying test procedure is to check whether a point-to-point PLC communication can be established and maintained in the presence of certain disturbances. The idea is to see whether the frames can be received correctly or not for the proposed test cases.						
	For each configuration tested, fill in a table as the example given below the performances obtained:						
	Noise amplitude (Vrms)	0,1	...				
	Signal amplitude (Vrms)	1	...				
	SNR (dB)	20	...				
	central frequency	66kHz	...				
	bandwidth of the noise	5kHz	...				
	Frame error rate (frame length = xx bytes)				
Bit error rate							
History	February 2010	Origin	OPEN METER WP4.1	Interface	MI1-C11	Applicable	Electricity Meter/communication hub, concentrator

Test case ID	3.4.1.7	Type of test	Performance test
Description	<p>This test tries to resolve which is the behavior of PLC technology in the presence of periodic disturbance. This scenario tries to emulate some real-world problems which will be found in real deployments. The result of these test may show the robustness of PLC technology, and maybe allow their improvement if they are not frozen yet.</p> <p>In AC lines there is a strong correlation between the presence of interfering noise and the zero crossings of the AC phases. This is due to the current consumption pattern of rotating AC motors and other equipment.</p> <p>The three AC phases have 6 zero crossings every 50msec cycle. As a result of this the pattern is a 120Hz signal (one crossing every 8.33msec).</p>		

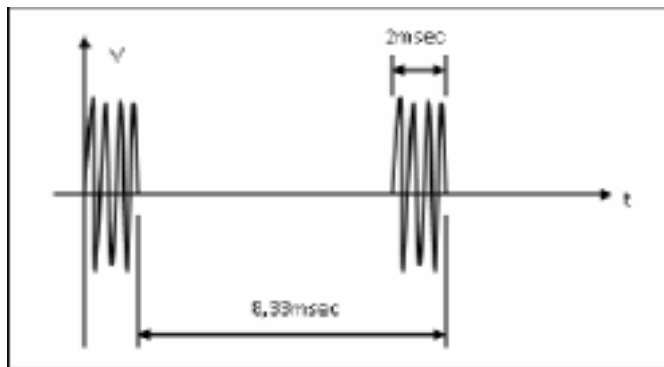

Figure1. Interfering signal for periodic disturbance tests

Technology / Protocol	PLC Technologies		
Test Environment	Laboratory X	Field (prototypes in paralell) <input type="checkbox"/>	Field (Substituted Meters) <input type="checkbox"/>

Pre-conditions

NOTE: It is important to respect exactly the schematics proposed below during the measurements and tests, and not to add any additional device, because this would change the impedance and therefore disturb the precision of the measurements. (NB: the schematics have been designed so that the impedance on the server side is always the same)

Testing configuration :

1/ Signal level measurement :

The Master must be set in continuous transmission mode (special continuous



Energy Theme; Grant Agreement No 226369

Title: Definition of Test procedures

Version: 0.4

Page: 33 / 110

transmission mode, or normal transmission with no pause between frames). The measurement must be done in RMS, not with peak value, with a bandwidth exceeding the bandwidth of the transmitter.

$$S_0 = S_{meas} - 6dB$$

S_0 : signal level

S_{meas} : signal level measured with spectrum analyzer.

Attn: 20 dB

Important warning regarding the IEC 61334-5-1 standard:

The IEC 61334-5-1 standard takes into account the energy received for a bit instead of the power received. This measurement method is not valid here because the signal level is not unlimited, but it must be below the maximum described in EN 50065-1 standard

2/ Error rate measurement with noise:

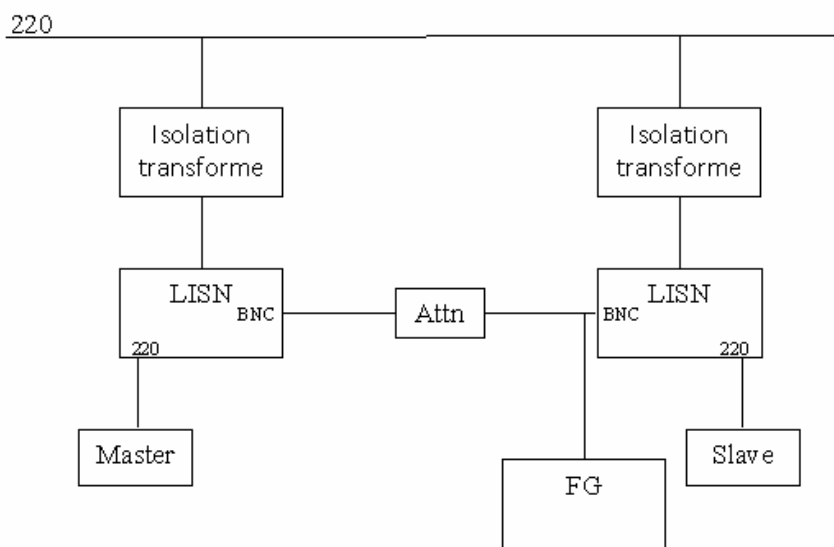

Attn: 20 dB

Steps

Description of the test :

By the means of a function generator, a periodic noise is introduced in the network.

The interfering signal can be modeled as a 10KHz signal active for 2msec, with a repetition interval of 8,33msec (TO BE agreed).

The test shall test the ability of PLC PHY to perform communications in the presence of a signal as depicted in figure 1, with the following amplitude levels (to be agreed):

- 100mVpeak for the sine part.
- 1Vpeak for the sine part.
- 5Vpeak for the sine part.

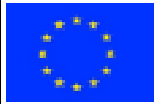

Energy Theme; Grant Agreement No 226369

Title: Definition of Test procedures

Version: 0.4

Page: 34 / 110

	<p>Unidirectional communication between the master and the slave. It is possible through a sniffer to count the number of frames exchanged between the master and the slave. In this case, 1000 frames will be sent for statistics purposes</p> <p>This test has to be performed for all the modulation schemes, all the different speed and different payload sizes, according to what is available for the tested technology.</p> <p>NOTE 1: If there are some reasons to think that the communication performances are not the same in the way Master to slave than in the way Slave to Master, this test has to be passed twice:</p> <ul style="list-style-type: none"> - Unidirectional communication from master to slave - Unidirectional communication from slave to master (with FG placed next to Master instead) 																																									
Requeriments	OM-CR 3	When PLC is used, the minimum speed must be 2.4 kbps for a reliable communication				Minimum																																				
	OM-CR 4	A reliable faster PLC interface should be possible.				Optional																																				
	OM-GR19	System must be robust				Minimum																																				
Fit criterion	<p>This test aims only at the PHY layer of PLC technology, and the underlying test procedure is to check whether a point-to-point PLC communication can be established and maintained in the presence of certain disturbances. The idea is to see whether the frames can be received correctly or not for the proposed test cases.</p> <p>For each configuration tested, fill in a table as the example given below the performances obtained:</p> <table border="1" style="width: 100%; border-collapse: collapse;"> <tr> <td style="width: 30%;">Signal amplitude (Vrms)</td> <td style="width: 10%;">1</td> <td style="width: 10%;">...</td> <td style="width: 10%;"></td> <td style="width: 10%;"></td> <td style="width: 10%;"></td> <td style="width: 10%;"></td> </tr> <tr> <td>Noise peak value (Vrms)</td> <td>5</td> <td>...</td> <td></td> <td></td> <td></td> <td></td> </tr> <tr> <td>Noise period</td> <td></td> <td>...</td> <td></td> <td></td> <td></td> <td></td> </tr> <tr> <td>Frame error rate (frame length = xx bytes)</td> <td>...</td> <td>...</td> <td></td> <td></td> <td></td> <td></td> </tr> <tr> <td>Bit error rate</td> <td></td> <td></td> <td></td> <td></td> <td></td> <td></td> </tr> </table>							Signal amplitude (Vrms)	1	...					Noise peak value (Vrms)	5	...					Noise period		...					Frame error rate (frame length = xx bytes)					Bit error rate						
Signal amplitude (Vrms)	1	...																																								
Noise peak value (Vrms)	5	...																																								
Noise period		...																																								
Frame error rate (frame length = xx bytes)																																								
Bit error rate																																										
History	February 2010	Origin	OPEN METER WP4.1	Inter face	MI1-C11	Applicable	Electricity Meter/communication hub, concentrator																																			

Test case ID	3.4.1.8	Type of test	Performance test
Description	This test is based on normative tests witch are compulsory requirements for CE marking of any device tested in the EU under IEC61000 reference normatives.		



Energy Theme; Grant Agreement No 226369

Title: Definition of Test procedures

Version: 0.4

Page: 35 / 110

	<p>However, it is based on real interference scenarios which are quite common in field operation.</p> <p>The IEC61000 standards impose certain levels and criteria for guaranteeing compliance. The purpose of this test is to gain advantage of this experience, and to verify how PLC technology performs under these phenomena.</p> <p>In this test the interfering signal consists of bursts of pulses of 15msec, with a interspace between bursts of 300msec. Each burst consists on a sequence of pulsed with a repetition rate of 5KHz (to be agreed).</p>						
Technology / Protocol	PLC Technologies						
Test Environment	Laboratory <input type="checkbox"/>	Field (prototypes in paralell) X			Field (Substituted Meters) <input type="checkbox"/>		
Pre-conditions	<p>This test is easy to prepare and execute, as there is specialized test equipment and laboratories available which offer them for CE marking purposes. As a result of this, the test should be done physically in a real environment with PLC devices.</p> <p>The test frame transmitted in each case should be the sequence of test frames with all the modulation schemes, with and without convolutional encoder, and different payload sizes, according to the sequence defined in the PLC protocol</p>						
Steps	<p>The goal is to verify how PLC communications can cope with the following levels while performing communications, at maximum output power level (to be agreed):</p> <ul style="list-style-type: none"> • 0,5KV crest voltage, with a repetition rate of 5KHz. • 1KV crest voltage, with a repetition rate of 5KHz. 						
Requeriments	OM-CR 3	When PLC is used, the minimum speed must be 2.4 kbps for a reliable communication				Minimum	
	OM-CR 4	A reliable faster PLC interface should be possible.				Optional	
	OM-GR19	System must be robust				Minimum	
Fit criterion	<p>This test aims only at the PHY layer of PLC technology, and the underlying test procedure is to check whether a point-to-point PLC communication can be established and maintained in the presence of certain disturbances.</p> <p>The idea is to see whether the frames can be received correctly or not for the proposed test cases.</p>						
History	February 2010	Origin	OPEN METER WP4.1	Inter face	MI1-C11	Applicable	Electricity Meter/communication hub, concentrator

Test case ID	3.4.1.9	Type of test	Performance test
Description	<p>This test is based on normative tests witch are compulsory requirements for CE marking of any device tested in the EU under IEC61000 reference normatives. However, it is based on real interference scenarios which are quite common in field operation.</p>		



Energy Theme; Grant Agreement No 226369

Title: Definition of Test procedures

Version: 0.4

Page: 36 / 110

	<p>The IEC61000 standards impose certain levels and criteria for guaranteeing compliance. The purpose of this test is to gain advantage of this experience, and to verify how PLC technology performs under these phenomena.</p> <p>In this test the PLC device withstands a conducted noise in its AC power port, in the frequency range of 150KHz to 80MHz, modulated with a 1KHz tone.</p> <p>Even though these signals are out of PLC frequency band, this kind of test may be very helpful to check how severe interference can affect PHY layer performance, as a measure of sensitivity to BER increase,</p>						
Technology / Protocol	PLC Technologies						
Test Environment	Laboratory <input type="checkbox"/>	Field (prototypes in paralell) X			Field (Substituted Meters) <input type="checkbox"/>		
Pre-conditions	<p>This test is easy to prepare and execute, as there is specialized test equipment and laboratories available which offer them for CE marking purposes. As a result of this, the test should be done physically in a real environment with PLC devices.</p> <p>The test frame transmitted in each case should be the sequence of test frames with all the modulation schemes, with and without convolutional encoder, and different payload sizes, according to the sequence defined in the PLC protocol</p>						
Steps	<p>The PLC communication must be verified with the impedance specified in IEC61000-4-6, and the following values shall be tested (to be agreed)</p> <ul style="list-style-type: none"> • Radiofrequency voltage level of 1Vrms. • Radiofrequency voltage level of 3Vrms. 						
Requeriments	OM-CR 3	When PLC is used, the minimum speed must be 2.4 kbps for a reliable communication				Minimum	
	OM-CR 4	A reliable faster PLC interface should be possible.				Optional	
	OM-GR19	System must be robust				Minimum	
Fit criterion	<p>This test aims only at the PHY layer of PLC technology, and the underlying test procedure is to check whether a point-to-point PLC communication can be established and maintained in the presence of certain disturbances.</p> <p>The idea is to see whether the frames can be received correctly or not for the proposed test cases.</p>						
History	February 2010	Origin	OPEN METER WP4.1	Inter face	MI1-C11	Applicable	Electricity Meter/communication hub, concentrator

Test case ID	3.4.1.10	Type of test	Performance test
Description	<p>This test is based on normative tests witch are compulsory requirements for CE marking of any device tested in the EU under IEC61000 reference normatives. However, it is based on real interference scenarios which are quite common in field</p>		



Energy Theme; Grant Agreement No 226369

Title: Definition of Test procedures

Version: 0.4

Page: 37 /
110

	<p>operation. The IEC61000 standards impose certain levels and criteria for guaranteeing compliance. The purpose of this test is to gain advantage of this experience, and to verify how PLC technology performs under these phenomena.</p> <p>This test consists on a sine wave of high amplitude which is exponentially damped, and has a repetition period depending on the impedance of the line (TO BE agreed).</p> <p>This is a phenomenon which is common in electrical substations and industrial appliances, where heavy electric loads are connected or disconnected. These perturbations usually affect all the electronics, since it is quite difficult to isolate an interference of this type. This test is usually performed both in common mode (line and neutral referred to ground) and differential mode (line to neutral), and both with positive and negative polarity.</p>						
Technology / Protocol	PLC Technologies						
Test Environment	Laboratory <input type="checkbox"/>	Field (prototypes in paralell) X			Field (Substituted Meters) <input type="checkbox"/>		
Pre-conditions	<p>This test is easy to prepare and execute, as there is specialized test equipment and laboratories available which offer them for CE marking purposes. As a result of this, the test should be done physically in a real environment with PLC devices.</p> <p>The test frame transmitted in each case should be the sequence of test frames with all the modulation schemes, with and without convolutional encoder, and different payload sizes, according to the sequence defined in PLC test procedures.</p>						
Steps	<p>The following tests shall be performed: (to be agreed)</p> <ul style="list-style-type: none"> • 0.5KV in common mode and 0.25KV in differential mode. • 1KV in common mode and 0.5KV in differential mode. <p>As this perturbation can only be generated with a period of 1 second, in this case a burst of PLC frames of the same type shall be generated, in order to detect whether the stress results in data or frame loss.</p>						
Requeriments	OM-GR19	System must be robust			Minimum		
Fit criterion	<p>This test aims only at the PHY layer of PLC technology, and the underlying test procedure is to check whether a point-to-point PLC communication can be established and maintained in the presence of certain disturbances.</p> <p>The idea is to see whether the frames can be received correctly or not for the proposed test cases.</p>						
History	February 2010	Origin	OPEN METER WP4.1	Interface	MI1-C11	Applicable	Electricity Meter/communication hub, concentrator



Test case ID	3.4.1.11	Type of test	functional
Description	This test measures the side effects of the crosstalk in the PLC network.		
Technology / Prorocol	PLC Technologies		
Test Environment	Laboratory X	Field (prototypes in paralell) <input type="checkbox"/>	Field (Substituted Meters) <input type="checkbox"/>
Pre-conditions	<p><u>Testing configuration :</u></p>		
Steps	<p><u>Description of the test :</u></p> <p>Between two isolated electrical networks, a variable coupling system (inductive coupler plus a variable attenuator) is added. At the very beginning the value A_{max} (in dB) of the attenuation is the highest possible, therefore there is no crosstalk at all in the network; then, the value of the variable attenuator is decreased. As soon as the first effects (such as communication interferences, register and switching issues,...) of the crosstalk on the neighbouring network appear, the value A_{crosstalk} of the attenuation (in dB) provides the level of immunity.</p> <p>IDENTIFIED GAP: The schematic of the coupler has to be defined more precisely</p>		



Energy Theme; Grant Agreement No 226369

Title: Definition of Test procedures

Version: 0.4

Page: 39 / 110

Requeriments	OM-CR 11	In case of having several PLC signals, due to crosstalk, it should not make communication impossible					Minimum
Fit criterion	This test aims only at the PHY layer of PLC technology, and the underlying test procedure is to check whether a point-to-point PLC communication can be established and maintained in the presence of certain disturbances. The idea is to see whether the frames can be received correctly or not for the proposed test cases.						
	Level of immunity = $A_{max} - A_{crosstalk}$						
History	April 2010	Origin	OPEN METER WP4.1	Inter face	MI1-C11	Applicable	Electricity Meter/ concentrator

Test case ID	3.4.1.12		Type of test	conformance
Description	This test observes the behaviour of the PLC modem when a low impedance circuit is added after the AFE.			
Technology / Prorocol	PLC Technologies			
Test Environment	Laboratory X	Field (prototypes in paralell) <input type="checkbox"/>	Field (Substituted Meters) <input type="checkbox"/>	
Pre-conditions	<p>Testing configuration :</p> <pre> graph TD A[220V] --- B[Isolation transformer] B --- C[LISN BNC] C --- D[Master] C --- E[2 ohms load] C --- F[Spectrum analyzer] </pre> <p>Schematics of the 2 ohms load:</p>			



Steps	<p>Description of the test :</p> <p>The node shall be capable of injecting a final signal level in the transmission network, which includes the low impedance circuit, respecting the EN 50065-1 standard emission limits.</p>						
Requeriments	OM-CR 3	When PLC is used, the minimum speed must be 2.4 kbps for a reliable communication				Minimum	
	OM-CR 4	A reliable faster PLC interface should be possible.				Optional	
Fit criterion	The measurement must show that no part of the spectrum of the signal exceeds 120dBμVrms.						
History	April 2010	Origin	OPEN METER WP4.1	Inter face	MI1-C11	Applicable	Electricity Meter/ concentrator

Test case ID	3.4.1.13			Type of test	conformance		
Description	Verify that all technologies can coexist in the same branch of the network.						
Technology / Prorocol	PLC Technologies						
Test Environment	Laboratory X	Field (prototypes in paralell) <input type="checkbox"/>			Field (Substituted Meters) <input type="checkbox"/>		
Pre-conditions							
Steps	Identified gap: to be defined the process of coexistence						
Requeriments	OM-CR 12	New PLC technologies defined in this project and PLC technologies compliant to standards used within this project should permit coexistence in the same network				Minimum	
Fit criterion	.						
History	April 2010	Origin	OPEN METER WP4.1	Inter face	MI1-C11	Applicable	Electricity Meter/ concentrator



Energy Theme; Grant Agreement No 226369

Title: Definition of Test procedures

Version: 0.4

Page: 41 / 110

Test case ID	3.4.1.14		Type of test	functional			
Description	GAP identified (since this mechanism is inherent for each type of technology)						
Technology / Protocol	PLC Technologies						
Test Environment	Laboratory X	Field (prototypes in parallel) <input type="checkbox"/>		Field (Substituted Meters) <input type="checkbox"/>			
Pre-conditions							
Steps							
Requirements	OM-CR 7	A phase detection mechanism must be supported			Minimum		
Fit criterion	.						
History	April 2010	Origin	OPEN METER WP4.1	Interface	MI1-C11	Applicable	Electricity Meter/ concentrator

3.4.2 Data - Link layer tests

It is necessary to perform tests directly above the DL layer in order to verify the robustness of the specifications and establish the performances of their implementations. Such tests allow to avoid the extra delays and uncertainties of the upper layers, in particular when the products implementing OFDM PLC technologies use different communication stacks. This method is needed to compare properly different OFDM PLC technologies, especially regarding useful throughput, efficiency and robustness facing network topology changes or problems due to the physical medium.

The objective of the tests described below is not to test all data link layer functionalities but to focus on the main functional features of the technology.

DL layer tests set :

2. Data Link layer
DL 2.1. Plug and Play registering
DL 2.2. Reaction to network topology changes
DL 2.3. Useful data throughput
DL 2.4. Priority management

Note: For all tests, each LISN (Line Impedance Stabilisation Network) must be connected on an isolation transformer, as shown below.

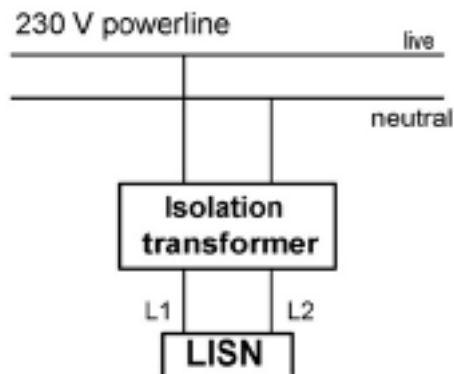

Test case ID	3.4.2.1	Type of test	functional interoperability
Description	Verify the plug and play registering behaviour of the PLC prototypes.		
Technology / Protocol	PLC technologies		
Test Environment	Laboratory X	Field (prototypes in paralell) <input type="checkbox"/>	Field (Substituted Meters) <input type="checkbox"/>
Pre-conditions	<p>Testing configuration :</p>		
Steps	<p>Description of the test :</p> <p><i>Important note: before performing each test, all products (masters and slaves) have to be reset to initial configuration.</i></p> <p>SCENARIO 1 :</p> <ul style="list-style-type: none"> - Set all attenuators to 0 dB, then power on all products (t = t₀). - Wait until the master has registered all slaves. <p>SCENARIO 2 :</p> <ul style="list-style-type: none"> - In order to change some slaves' roles (terminal or switch) set all attenuators to pertinent values (refer to test [PHY 1.2]). Then, power on all products (t = t₀). - Wait until the master has registered all slaves. 		



Energy Theme; Grant Agreement No 226369

Title: Definition of Test procedures

Version: 0.4

Page: 43 / 110

Requeriments	OM-CR 6	Automatic meter detection must be supported				Minimum																																																						
Fit criterion	For each SCENARIO, fill in a table as the example given below :																																																											
	<table border="1"> <thead> <tr> <th>Time t0</th> <td colspan="5">29-04-2009 – 13:00:32</td> </tr> <tr> <th>Slave ID</th> <th>Registering time and date t</th> <th>$\Delta t = t - t_0$</th> <th colspan="3">role</th> </tr> </thead> <tbody> <tr> <td>S1</td> <td>29-04-2009 – 13:01:23</td> <td>0 h 0 min 51 s</td> <td colspan="3">Not repeater</td> </tr> <tr> <td>S2</td> <td>29-04-2009 – 14:00:32</td> <td>1 h 0 min 0 s</td> <td colspan="3">Not repeater</td> </tr> <tr> <td>S3</td> <td>29-04-2009 – 14:01:32</td> <td>1 h 1 min 0 s</td> <td colspan="3">Repeater</td> </tr> <tr> <td>S4</td> <td>30-04-2009 – 03:00:32</td> <td>14 h 0 min 0 s</td> <td colspan="3">Repeater</td> </tr> <tr> <td>S5</td> <td>30-04-2009 – 12:06:32</td> <td>23 h 6 min 0 s</td> <td colspan="3">Not repeater</td> </tr> </tbody> </table> <p>In addition, it is necessary to join a table listing the different attenuation values as the example given below :</p> <table border="1"> <thead> <tr> <th>Attenuator ID</th> <th>Attenuation value</th> </tr> </thead> <tbody> <tr> <td>Att.1</td> <td>10 dB</td> </tr> <tr> <td>Att.2</td> <td>0 dB</td> </tr> <tr> <td>Att.3</td> <td>29 dB</td> </tr> <tr> <td>Att.4</td> <td>...</td> </tr> <tr> <td>Att.5</td> <td>...</td> </tr> </tbody> </table>						Time t0	29-04-2009 – 13:00:32					Slave ID	Registering time and date t	$\Delta t = t - t_0$	role			S1	29-04-2009 – 13:01:23	0 h 0 min 51 s	Not repeater			S2	29-04-2009 – 14:00:32	1 h 0 min 0 s	Not repeater			S3	29-04-2009 – 14:01:32	1 h 1 min 0 s	Repeater			S4	30-04-2009 – 03:00:32	14 h 0 min 0 s	Repeater			S5	30-04-2009 – 12:06:32	23 h 6 min 0 s	Not repeater			Attenuator ID	Attenuation value	Att.1	10 dB	Att.2	0 dB	Att.3	29 dB	Att.4	...	Att.5	...
Time t0	29-04-2009 – 13:00:32																																																											
Slave ID	Registering time and date t	$\Delta t = t - t_0$	role																																																									
S1	29-04-2009 – 13:01:23	0 h 0 min 51 s	Not repeater																																																									
S2	29-04-2009 – 14:00:32	1 h 0 min 0 s	Not repeater																																																									
S3	29-04-2009 – 14:01:32	1 h 1 min 0 s	Repeater																																																									
S4	30-04-2009 – 03:00:32	14 h 0 min 0 s	Repeater																																																									
S5	30-04-2009 – 12:06:32	23 h 6 min 0 s	Not repeater																																																									
Attenuator ID	Attenuation value																																																											
Att.1	10 dB																																																											
Att.2	0 dB																																																											
Att.3	29 dB																																																											
Att.4	...																																																											
Att.5	...																																																											
History	April 2010	Origin	OPEN METER WP4.1	Inter face	MI1-C11	Applicable	Electricity Meter/ concentrator																																																					

Test case ID:	3.4.2.2	Type of test	Functional interoperability
Description	Verify the behaviour of the PLC prototypes, when network topology changes		
Technology / Prorocol	PLC technologies		
Test Environment	Laboratory X	Field (prototypes in paralell) <input type="checkbox"/>	Field (Substituted Meters) <input type="checkbox"/>
Pre-conditions	<p>Testing configurations :</p> <p>SCENARIO 1 to 4 :</p> <p>SCENARIO 5 :</p>		



	<p style="text-align: right;">230 V powerline</p> $AttM1 = \sum_{i=1}^3 Att_i$ $AttM2 = \sum_{i=4}^6 Att_i$
<p>Steps</p>	<p>. Description of the test :</p> <p>Important note: before performing each test, all products (masters and slaves) have to be reset to initial configuration.</p> <p>SCENARIO 1 :</p> <ul style="list-style-type: none"> - All attenuators must be set to the same values defined in test [DL 2.1 – SCENARIO 2], then power on all products (t = t₀). - Wait until the master has registered all slaves. - Power off a device among the slaves. - Try to communicate with each slave by sending a control message from the master. <p>SCENARIO 2 :</p> <ul style="list-style-type: none"> - All attenuators must be set to the same values defined in test [DL 2.1 – SCENARIO 2], then power on all products. - Wait until the master has registered all slaves. - Power off a device “Si” among the slaves performing switch function (t = t₀). - Wait until the master has updated the registered slaves table. - Verify that communication between the master and the switched-off “Si” slave is impossible. - Set the attenuator “Att. i+1” to 0 dB (t = t₁).- Wait until the master has registered all slaves (except “Si” slave). <p>SCENARIO 3 :</p> <ul style="list-style-type: none"> - All attenuators must be set to the same values defined in test [DL 2.1 – SCENARIO 2], then power on all products. - Wait until the master has registered all slaves. -Power off a device “Si” among the slaves performing switch function (t = t₀). <ul style="list-style-type: none"> - Wait until the master has updated the registered slaves table. - Verify that communication between the master and the switched-off “Si” slave is impossible.



Energy Theme; Grant Agreement No 226369

Title: Definition of Test procedures

Version: 0.4

Page: 45 / 110

- Power on device "Si" (t = t1).
- Wait until the master has registered all slaves.

SCENARIO 4 :

- All attenuators must be set to the same values defined in test [DL 2.1 – SCENARIO 2], then power on all products (t = t0).
- Wait until the master has registered all slaves.
- Power off the master device and replace it by another master device.
- Power on the new master device (t = t1).
- Wait until the master has registered all slaves.
- Try to communicate with each slave by sending a control message from the master.

SCENARIO 5 :

- Attenuators Att. 1 to Att. 3 must be set to 0 dB, and attenuators Att. 4 to Att. 6 must be set to their maximum value, then power on all products (t = t0).

All along the test, the registering state (registered/unregistered) of slave S3 should be observed in the registered slave tables of masters 1 and 2 (observe also the evolution of S3 registering state locally, i.e. on the S3 slave's user interface).

- Decrease gradually the global attenuation value of Att. M2 : with steps of 1 dB decrease Att. 1 first, then Att. 2 and Att. 3. This cycle has to be repeated until Att. M2 = 0 dB.
- Increase gradually the global attenuation value of Att. M1 : with steps of 1 dB increase Att. 6 first, then Att. 5 and Att. 4. This cycle has to be repeated until reaching the Att. M1 maximum value.

It is important to alternate Att. M2 decreasing and Att. M1 increasing.

Requeriments	OM-CR 8	Adaption to topology changes must be supported	Minimum
---------------------	---------	--	---------

Fit criterion	<p>For each SCENARIO, fill in the table as the example given below :</p> <p>SCENARIO 1</p> <p>Fill in a table as the example given below :</p> <table border="1"> <thead> <tr> <th>Time t0</th> <th colspan="3">29-04-2009 – 13:00:32</th> </tr> <tr> <th>Slave ID</th> <th>Registering time and date t</th> <th>$\Delta t = t - t_0$</th> <th>role</th> </tr> </thead> <tbody> <tr> <td>S1</td> <td>29-04-2009 – 13:01:23</td> <td>0 h 0 min 51 s</td> <td>Not repeater</td> </tr> <tr> <td>S2</td> <td>29-04-2009 – 14:00:32</td> <td>1 h 0 min 0 s</td> <td>Repeater</td> </tr> <tr> <td>S3</td> <td>29-04-2009 – 14:01:32</td> <td>1 h 1 min 0 s</td> <td>Repeater</td> </tr> <tr> <td>S4</td> <td>30-04-2009 – 03:00:32</td> <td>14 h 0 min 0 s</td> <td>Repeater</td> </tr> <tr> <td>S5</td> <td>30-04-2009 – 12:06:32</td> <td>23 h 6 min 0 s</td> <td>Not repeater</td> </tr> </tbody> </table> <p>For each slave, mention if the communication trial succeeded or not.</p> <p>In addition, it is necessary to join a table listing the different attenuation values as the example given below :</p> <table border="1"> <thead> <tr> <th>Attenuator ID</th> <th>Attenuation value</th> </tr> </thead> <tbody> <tr> <td>Att.1</td> <td>10 dB</td> </tr> <tr> <td>Att.2</td> <td>0 dB</td> </tr> <tr> <td>Att.3</td> <td>29 dB</td> </tr> <tr> <td>Att.4</td> <td>...</td> </tr> </tbody> </table>			Time t0	29-04-2009 – 13:00:32			Slave ID	Registering time and date t	$\Delta t = t - t_0$	role	S1	29-04-2009 – 13:01:23	0 h 0 min 51 s	Not repeater	S2	29-04-2009 – 14:00:32	1 h 0 min 0 s	Repeater	S3	29-04-2009 – 14:01:32	1 h 1 min 0 s	Repeater	S4	30-04-2009 – 03:00:32	14 h 0 min 0 s	Repeater	S5	30-04-2009 – 12:06:32	23 h 6 min 0 s	Not repeater	Attenuator ID	Attenuation value	Att.1	10 dB	Att.2	0 dB	Att.3	29 dB	Att.4	...
Time t0	29-04-2009 – 13:00:32																																								
Slave ID	Registering time and date t	$\Delta t = t - t_0$	role																																						
S1	29-04-2009 – 13:01:23	0 h 0 min 51 s	Not repeater																																						
S2	29-04-2009 – 14:00:32	1 h 0 min 0 s	Repeater																																						
S3	29-04-2009 – 14:01:32	1 h 1 min 0 s	Repeater																																						
S4	30-04-2009 – 03:00:32	14 h 0 min 0 s	Repeater																																						
S5	30-04-2009 – 12:06:32	23 h 6 min 0 s	Not repeater																																						
Attenuator ID	Attenuation value																																								
Att.1	10 dB																																								
Att.2	0 dB																																								
Att.3	29 dB																																								
Att.4	...																																								



Energy Theme; Grant Agreement No 226369

Title: Definition of Test procedures

Version: 0.4

Page: 46 / 110

Att.5	...
-------	-----

SCENARIO 2

Before t1 :

Time t0	29-04-2009 – 13:00:32		
Slave ID	Registering time and date t	$\Delta t = t - t_0$	role
S1	29-04-2009 – 13:01:23	0 h 0 min 51 s	Not repeater
S2	29-04-2009 – 14:00:32	1 h 0 min 0 s	Not repeater
S3	Powered off	-----	Repeater
S4	Unregistered	-----	Repeater
S5	Unregistered	-----	Not repeater

After t1 :

Time t1	29-04-2009 – 14:10:32		
Slave ID	Registering time and date t	$\Delta t = t - t_1$	role
S1	29-04-2009 – 13:01:23	0 h 0 min 0 s	Not repeater
S2	29-04-2009 – 14:00:32	0 h 0 min 0 s	Not repeater
S3	Powered off	-----	Not repeater
S4	29-04-2009 – 14:12:32	0 h 2 min 0 s	Repeater
S5	29-04-2009 – 15:06:32	0 h 56 min 0 s	Not repeater

In addition, it is necessary to join a table listing the different attenuation values as the example given below :

Attenuator ID	Attenuation value
Att.1	10 dB
Att.2	0 dB
Att.3	29 dB
Att.4	...
Att.5	...

SCENARIO 3

Fill in two tables as the example given below :

Before t1 :

Time t0	29-04-2009 – 13:00:32		
Slave ID	Registering time and date t	$\Delta t = t - t_0$	role
S1	29-04-2009 – 13:01:23	0 h 0 min 51 s	Repeater
S2	29-04-2009 – 14:00:32	1 h 0 min 0 s	...
S3	Powered off	-----	
S4	Unregistered	-----	
S5	Unregistered	-----	

After t1 :



Energy Theme; Grant Agreement No 226369

Title: Definition of Test procedures

Version: 0.4

Page: 47 / 110

Time t1	29-04-2009 – 14:10:32		
Slave ID	Registering time and date t	$\Delta t = t - t1$	role
S1	29-04-2009 – 13:01:23	0 h 0 min 0 s	Repeater
S2	29-04-2009 – 14:00:32	0 h 0 min 0 s	...
S3	29-04-2009 – 14:11:00	0 h 0 min 28 s	
S4	29-04-2009 – 14:12:32	0 h 2 min 0 s	
S5	29-04-2009 – 15:06:32	0 h 56 min 0 s	

In addition, it is necessary to join a table listing the different attenuation values as the example given below :

Attenuator ID	Attenuation value
Att.1	10 dB
Att.2	0 dB
Att.3	29 dB
Att.4	...
Att.5	...

SCENARIO 4

Fill in a table as the example given below :

Before t1 :

Time t0	29-04-2009 – 13:00:32		
Slave ID	Registering time and date t	$\Delta t = t - t0$	role
S1	29-04-2009 – 13:01:23	0 h 0 min 51 s	Repeater
S2	29-04-2009 – 14:00:32	1 h 0 min 0 s	Repeater
S3
S4
S5

After t1 :

Time t1	30-04-2009 – 13:00:32		
Slave ID	Registering time and date t	$\Delta t = t - t1$	role
S1	30-04-2009 – 13:01:23	0 h 0 min 51 s	Repeater
S2	30-04-2009 – 14:00:32	1 h 0 min 0 s	Repeater
S3
S4
S5

For each slave, mention if the communication trial succeeded or not.

In addition, it is necessary to join a table listing the different attenuation values as the example given below :

Attenuator ID	Attenuation value
Att.1	10 dB
Att.2	0 dB
Att.3	29 dB
Att.4	...
Att.5	...



	SCENARIO 5						
	Observe the evolution of slave S3 in the registered slave tables.						
	Fill in a table as the example given below :						
	Time t0		30-04-2009 – 13:00:32				
	Att. M1 (dB)	Att. M2 (dB)	Registering time and date (precise master)			role	
	0	Max	30-04-2009 – 13:01:23 – master M1			Repeater	
	0	Max – 1	30-04-2009 – 13:04:32 – master M1			
	1	Max – 1	
	1	Max – 2	
	
Att. M1 = Att. M2			
...		
Max	0	30-04-2009 – 14:00:04 – master M2			...		
History	April 2010	Origin	OPEN METER WP4.1	Inter face	MI1-C11	Applicable	Electricity Meter/ concentrator

Test case ID	3.4.2.3		Type of test	Functional interoperability
Description	Determine the useful data throughput over the DL layer			
Technology / Prorocol	PLC technologies			
Test Environment	Laboratory X	Field (prototypes in paralell) <input type="checkbox"/>	Field (Substituted Meters) <input type="checkbox"/>	
Pre-conditions	<p>Testing configurations :</p> <p>SCENARIO 1 :</p> <p>SCENARIO 2 :</p>			

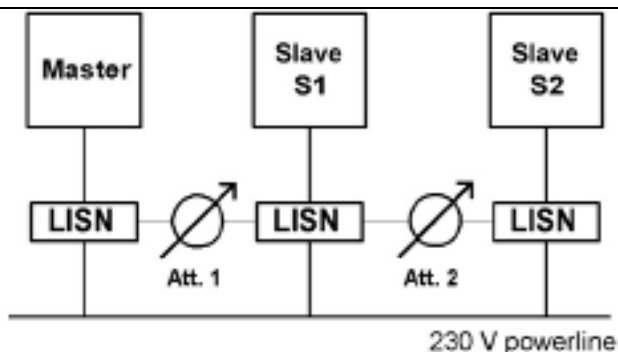

SCENARIO 3 and 4 :

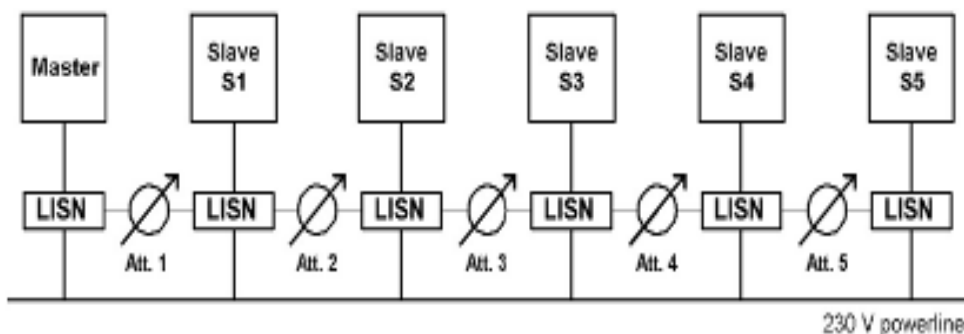

Steps

Description of the test :

Important note: before performing each test, all products (master and slaves) have to be reset to initial configuration.

SCENARIO 1 :

- Set all attenuators to 0 dB, then power on master and slave S1.
- Wait until the master has registered slave S1.
- Transfer a 50 kB sized .txt file from master to slave S1 (downstream)
- Transfer a 50 kB sized .txt file from slave S1 to master (upstream)
- Increase Att. 1 with steps of 1 dB until file transfer is no more possible (refer to test [PHY 1.2] to get the maximum attenuation value). Repeat downstream and upstream file transfers for each Att. 1 value.

SCENARIO 2 :

- Set all attenuators to 0 dB, then power on master and slave S1.
- Wait until the master has registered slave S1.
- Begin the transfer of a 2 MB .txt file from the master to slave S1 ($t = t_0$).
- Power on slave S2.
- Wait until the master has registered slave S2, and master to S1 file transfer is



Energy Theme; Grant Agreement No 226369

Title: Definition of Test procedures

Version: 0.4

Page: 50 / 110

completed.

SCENARIO 3 :

- All attenuators must be set to the same values defined in test [DL 2.1 – SCENARIO 2], then power on all products.
- Wait until the master has registered all slaves.
- Transfer a 2 MB .txt file from master to all slaves (downstream broadcast).

SCENARIO 4 :

- All attenuators must be set to the same values defined in test [DL 2.1 – SCENARIO 2], then power on all products (t = t0).
- Wait until the master has registered all slaves.
- Begin the transfer of a 2 MB .txt file from the master to slave S5.
- Power off a device “Si” among the slaves performing switch function.
- Wait until the master has updated the registered slaves table.
- Verify that communication between the master and the switched-off “Si” slave is impossible.
- Set the attenuator “Att. i+1” to 0 dB.
- Wait until the master has registered all slaves (except “Si” slave), and master to S5 file transfer is completed.

Requeriments	OM-CR 3	When PLC is used, the minimum speed must be 2.4 kbps for a reliable communication	Minimum
	OM-CR 4	A reliable faster PLC interface should be possible.	Optional

Fit criterion	SCENARIO 1:															
	Fill in a table as the example given below :	<table border="1"> <thead> <tr> <th>Att. 1</th> <th>Downstream data rate</th> <th>Downstream Bit Error Rate</th> <th>Upstream data rate</th> <th>Upstream Bit Error Rate</th> </tr> </thead> <tbody> <tr> <td>0</td> <td>10892 bps</td> <td>...</td> <td>...</td> <td>...</td> </tr> <tr> <td>1</td> <td>9878 bps</td> <td>...</td> <td>...</td> <td>...</td> </tr> </tbody> </table>	Att. 1	Downstream data rate	Downstream Bit Error Rate	Upstream data rate	Upstream Bit Error Rate	0	10892 bps	1	9878 bps
Att. 1	Downstream data rate	Downstream Bit Error Rate	Upstream data rate	Upstream Bit Error Rate												
0	10892 bps												
1	9878 bps												
	SCENARIO 2:															
	<p>During the test, observe the evolution of the master to slave S1 communication link's data rate and bit error rate. Write down the duration needed to register slave S2.</p> <p>In addition, it is necessary to join a table listing the different attenuation values as the example given below :</p> <table border="1"> <thead> <tr> <th>Attenuator ID</th> <th>Attenuation value</th> </tr> </thead> <tbody> <tr> <td>Att.1</td> <td>10 dB</td> </tr> <tr> <td>Att.2</td> <td>0 dB</td> </tr> </tbody> </table>	Attenuator ID	Attenuation value	Att.1	10 dB	Att.2	0 dB									
Attenuator ID	Attenuation value															
Att.1	10 dB															
Att.2	0 dB															
	SCENARIO 3:															
	<p>During the test, observe how the bandwidth is shared, by measuring the data rate on each slave, on significant durations. For each master to slave communication, the bit error rate must also be measured and written down.</p> <p>In addition, it is necessary to join a table listing the different attenuation values as the example given below :</p>															



Attenuator ID	Attenuation value
Att.1	10 dB
Att.2	0 dB
Att.3	29 dB
Att.4	...
Att.5	...

SCENARIO 4:

During the test, observe the evolution of the master to slave S5 communication link's data rate and bit error rate.

In addition, it is necessary to join a table listing the different attenuation values as the example given below :

Attenuator ID	Attenuation value
Att.1	10 dB
Att.2	0 dB
Att.3	29 dB
Att.4	...
Att.5	...

History	April 2010	Origin	OPEN METER WP4.1	Inter face	MI1-C11	Applicable	Electricity Meter/ concentrator
----------------	------------	---------------	------------------	-------------------	---------	-------------------	---------------------------------

Test case ID	3.4.2.4	Type of test	Functional interoperability
Description	Observe the behaviour of the system regarding priority management issues.		
Technology / Prorocol	PLC technologies		
Test Environment	Laboratory X	Field (prototypes in paralell) <input type="checkbox"/>	Field (Substituted Meters) <input type="checkbox"/>
Pre-conditions	<p>Testing configuration :</p>		
Steps	<p>Description of the test :</p> <p><i>Important note: before performing each test, all products (masters and slaves)</i></p>		



Energy Theme; Grant Agreement No 226369

Title: Definition of Test procedures

Version: 0.4

Page: 52 / 110

	<p>have to be reset to initial configuration.</p> <p>SCENARIO 1 :</p> <ul style="list-style-type: none"> - Set all attenuators to 0 dB, then power on all products. - Wait until the master has registered all slaves. - Begin the transfer of a 2 MB .txt file from the master to slave S5 (downstream). - Transfer a 1 kB .txt file with high priority from another slave “Si” to master (upstream). - Wait until the end of all file transfers. <p>SCENARIO 2 :</p> <ul style="list-style-type: none"> - All attenuators must be set to the same values defined in test [DL 2.1 – SCENARIO 2], then power on all products (t = t₀). - Wait until the master has registered all slaves. - Begin the transfer of a 2 MB .txt file from the master to slave S5 (downstream). - Transfer a 1 kB .txt file with high priority from another slave “Si” to master (upstream). - Wait until the end of all file transfers 																		
Requeriments	OM-CR XX																		
Fit criterion	<p>SCENARIO 1 and 2:</p> <p>During the test, observe the evolution of downstream and upstream data rates and bit error rates. Also check the behaviour of the master regarding the high priority transfer.</p> <p>In addition, it is necessary to join a table listing the different attenuation values as the example given below :</p> <table border="1" style="width: 100%; border-collapse: collapse;"> <thead> <tr> <th style="text-align: center;">Attenuator ID</th> <th style="text-align: center;">Attenuation value</th> </tr> </thead> <tbody> <tr> <td style="text-align: center;">Att.1</td> <td style="text-align: center;">10 dB</td> </tr> <tr> <td style="text-align: center;">Att.2</td> <td style="text-align: center;">0 dB</td> </tr> <tr> <td style="text-align: center;">Att.3</td> <td style="text-align: center;">29 dB</td> </tr> <tr> <td style="text-align: center;">Att.4</td> <td style="text-align: center;">...</td> </tr> <tr> <td style="text-align: center;">Att.5</td> <td style="text-align: center;">...</td> </tr> </tbody> </table>							Attenuator ID	Attenuation value	Att.1	10 dB	Att.2	0 dB	Att.3	29 dB	Att.4	...	Att.5	...
Attenuator ID	Attenuation value																		
Att.1	10 dB																		
Att.2	0 dB																		
Att.3	29 dB																		
Att.4	...																		
Att.5	...																		
History	April 2010	Origin	OPEN METER WP4.1	Inter face	MI1-C11	Applicable	Electricity Meter/ concentrator												



Energy Theme; Grant Agreement No 226369

Title: Definition of Test procedures

Version: 0.4

Page: 53 / 110

3.4.3 Functional use cases

This set of functional use cases aims at validating the use of PLC technologies from a metering application point of view.

3. Functional use cases
3.1. Registering procedure
3.2. Register reading
3.3. Load profile reading. The "load profile" of the meter must be with a step of 30 min on a 30 days period (to be fixed the load profile step according to the different partners)
3.4. Firmware update
3.5. Alarm functionalities

Test case ID	3.4.3.1	Type of test	Functional interoperability
Description	Verify the behaviour of the PLC prototypes' registering procedure.		
Technology / Protocol	PLC technologies		
Test Environment	Laboratory X	Field (prototypes in paralell) <input type="checkbox"/>	Field (Substituted Meters) <input type="checkbox"/>
Pre-conditions	<p><u>Testing configuration :</u></p>		
Steps	<p><u>Description of the test :</u></p> <p>Important note : before performing each test, all products (master and slaves) have to be reset to initial configuration.</p> <p>SCENARIO 1 :</p> <ul style="list-style-type: none"> - Set all attenuators to 0 dB, then power on all products (t = t₀). - Wait until the master has registered all slaves. 		

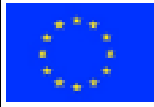

Energy Theme; Grant Agreement No 226369

Title: Definition of Test procedures

Version: 0.4

Page: 54 / 110

	SCENARIO 2 :																																							
	- All attenuators must be set to the same values defined in test [DL 2.1 – SCENARIO 2], then power on all products (t = t ₀).																																							
	- Wait until the master has registered all slaves.																																							
Requeriments	OM-CR XX																																							
Fit criterion	<p>SCENARIO 1 and 2:</p> <p>For each SCENARIO, fill in a table as the example given below :</p> <table border="1"> <thead> <tr> <th>Time t₀</th> <th colspan="2">29-04-2009 – 13:00:32</th> </tr> <tr> <th>Slave ID</th> <th>Registering time and date t</th> <th>Δt = t – t₀</th> </tr> </thead> <tbody> <tr> <td>S1</td> <td>29-04-2009 – 13:01:23</td> <td>0 h 0 min 51 s</td> </tr> <tr> <td>S2</td> <td>29-04-2009 – 14:00:32</td> <td>1 h 0 min 0 s</td> </tr> <tr> <td>S3</td> <td>29-04-2009 – 14:01:32</td> <td>1 h 1 min 0 s</td> </tr> <tr> <td>S4</td> <td>30-04-2009 – 03:00:32</td> <td>14 h 0 min 0 s</td> </tr> <tr> <td>S5</td> <td>30-04-2009 – 12:06:32</td> <td>23 h 6 min 0 s</td> </tr> </tbody> </table> <p>In addition, it is necessary to join a table listing the different attenuation values as the example given below :</p> <table border="1"> <thead> <tr> <th>Attenuator ID</th> <th>Attenuation value</th> </tr> </thead> <tbody> <tr> <td>Att.1</td> <td>10 dB</td> </tr> <tr> <td>Att.2</td> <td>0 dB</td> </tr> <tr> <td>Att.3</td> <td>29 dB</td> </tr> <tr> <td>Att.4</td> <td>...</td> </tr> <tr> <td>Att.5</td> <td>...</td> </tr> </tbody> </table>							Time t ₀	29-04-2009 – 13:00:32		Slave ID	Registering time and date t	Δt = t – t ₀	S1	29-04-2009 – 13:01:23	0 h 0 min 51 s	S2	29-04-2009 – 14:00:32	1 h 0 min 0 s	S3	29-04-2009 – 14:01:32	1 h 1 min 0 s	S4	30-04-2009 – 03:00:32	14 h 0 min 0 s	S5	30-04-2009 – 12:06:32	23 h 6 min 0 s	Attenuator ID	Attenuation value	Att.1	10 dB	Att.2	0 dB	Att.3	29 dB	Att.4	...	Att.5	...
Time t ₀	29-04-2009 – 13:00:32																																							
Slave ID	Registering time and date t	Δt = t – t ₀																																						
S1	29-04-2009 – 13:01:23	0 h 0 min 51 s																																						
S2	29-04-2009 – 14:00:32	1 h 0 min 0 s																																						
S3	29-04-2009 – 14:01:32	1 h 1 min 0 s																																						
S4	30-04-2009 – 03:00:32	14 h 0 min 0 s																																						
S5	30-04-2009 – 12:06:32	23 h 6 min 0 s																																						
Attenuator ID	Attenuation value																																							
Att.1	10 dB																																							
Att.2	0 dB																																							
Att.3	29 dB																																							
Att.4	...																																							
Att.5	...																																							
History	April 2010	Origin	OPEN METER WP4.1	Inter face	MI1-C11	Applicable	Electricity Meter/ concentrator																																	

Test case ID	3.4.3.2	Type of test	Functional interoperability
Description	Observe register reading performances.		
Technology / Prorocol	PLC technologies		
Test Environment	Laboratory X	Field (prototypes in paralell) <input type="checkbox"/>	Field (Substituted Meters) <input type="checkbox"/>
Pre-conditions	<u>Testing configuration :</u>		

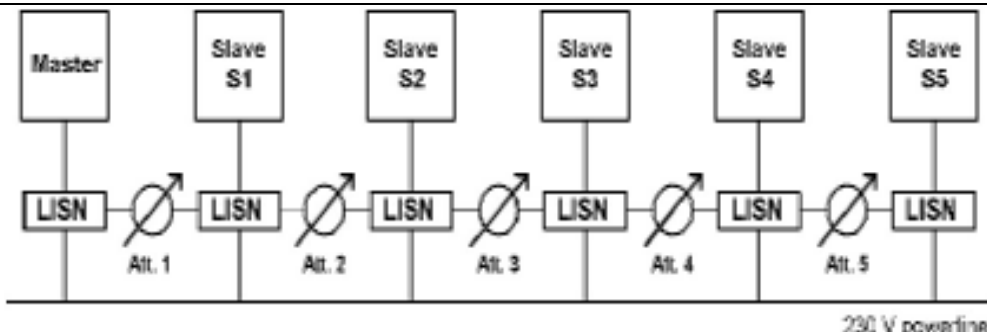

Steps

Description of the test :

Important note : before performing each test, all products (master and slaves) have to be reset to initial configuration

SCENARIO 1 :

- Set all attenuators to 0 dB, then power on all products.
- Wait until the master has registered all slaves.
- For each slave transmit a register reading request ($t = t_0$).
- Wait until the reception of each slave's response.

SCENARIO 2 :

- All attenuators must be set to the same values defined in test [DL 2.1 – SCENARIO 2], then power on all products.
- Wait until the master has registered all slaves.
- For each slave transmit a register reading request ($t = t_0$).
- Wait until the reception of each slave's response.

Requeriments OM-CR XX

Fit criterion

SCENARIO 1 and 2:

For each SCENARIO, fill in a table as the example given below :

Time t0	29-04-2009 – 13:00:32	
Slave ID	Responding time and date t	$\Delta t = t - t_0$
S1	29-04-2009 – 13:01:23	0 h 0 min 51 s
S2	29-04-2009 – 14:00:32	1 h 0 min 0 s
S3	29-04-2009 – 14:01:32	1 h 1 min 0 s
S4	30-04-2009 – 03:00:32	14 h 0 min 0 s
S5	30-04-2009 – 12:06:32	23 h 6 min 0 s

During the test, observe the evolution of the data rate (application layer point of view). In addition, it is necessary to join a table listing the different attenuation values as the example given below :



	Attenuator ID		Attenuation value				
	Att.1	10 dB					
	Att.2	0 dB					
	Att.3	29 dB					
	Att.4	...					
	Att.5	...					
History	April 2010	Origin	OPEN METER WP4.1	Inter face	MI1-C11	Applicable	Electricity Meter/ concentrator

Test case ID	3.4.3.3	Type of test	Functional interoperability
Description	Observe load profile reading performances.		
Technology / Prorocol	PLC technologies		
Test Environment	Laboratory X	Field (prototypes in paralell) <input type="checkbox"/>	Field (Substituted Meters) <input type="checkbox"/>
Pre-conditions	<p>Testing configuration :</p>		
Steps	<p>Description of the test :</p> <p>Important note : before performing each test, all products (master and slaves) have to be reset to initial configuration.</p> <p>The "load profile" of the meter must be with a step of 1 min (if possible) to fill the load profile with 1440 entries. For this test the slaves must already have enough stored registers to be able to deliver a load profile.</p> <p>The load profile shall be configured as follows: column 1: time stamp - column 2: status - column 3: active energy import - column 4 active energy export - column 5: reactive energy import - column 6: reactive energy export</p> <p>SCENARIO 1 :</p> <p>- Set all attenuators to 0 dB, then power on all products.</p>		

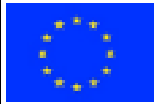

Energy Theme; Grant Agreement No 226369

Title: Definition of Test procedures

Version: 0.4

Page: 57 /
110

	<ul style="list-style-type: none"> - Wait until the master has registered all slaves. - For each slave transmit a load profile reading request (t = t₀). - Wait until the reception of each slave's response. <p>SCENARIO 2 :</p> <ul style="list-style-type: none"> - All attenuators must be set to the same values defined in test [DL 2.1 – SCENARIO 2], then power on all products. - Wait until the master has registered all slaves. - For each slave transmit a load profile reading request (t = t₀). - Wait until the reception of each slave's response. 																																							
Requeriments	OM-CR XX																																							
Fit criterion	<p>SCENARIO 1 and 2:</p> <p>For each SCENARIO, fill in a table as the example given below :</p> <table border="1" style="width: 100%; border-collapse: collapse;"> <thead> <tr> <th style="width: 15%;">Time t₀</th> <th colspan="2" style="text-align: center;">29-04-2009 – 13:00:32</th> </tr> <tr> <th style="width: 15%;">Slave ID</th> <th style="width: 45%;">Responding time and date t</th> <th style="width: 40%;">Δt = t – t₀</th> </tr> </thead> <tbody> <tr> <td>S1</td> <td>29-04-2009 – 13:01:23</td> <td>0 h 0 min 51 s</td> </tr> <tr> <td>S2</td> <td>29-04-2009 – 14:00:32</td> <td>1 h 0 min 0 s</td> </tr> <tr> <td>S3</td> <td>29-04-2009 – 14:01:32</td> <td>1 h 1 min 0 s</td> </tr> <tr> <td>S4</td> <td>30-04-2009 – 03:00:32</td> <td>14 h 0 min 0 s</td> </tr> <tr> <td>S5</td> <td>30-04-2009 – 12:06:32</td> <td>23 h 6 min 0 s</td> </tr> </tbody> </table> <p>During the test, observe the evolution of the data rate (application layer point of view).</p> <p>In addition, it is necessary to join a table listing the different attenuation values as the example given below :</p> <table border="1" style="width: 100%; border-collapse: collapse;"> <thead> <tr> <th style="width: 30%;">Attenuator ID</th> <th style="width: 70%;">Attenuation value</th> </tr> </thead> <tbody> <tr> <td>Att.1</td> <td>10 dB</td> </tr> <tr> <td>Att.2</td> <td>0 dB</td> </tr> <tr> <td>Att.3</td> <td>29 dB</td> </tr> <tr> <td>Att.4</td> <td>...</td> </tr> <tr> <td>Att.5</td> <td>...</td> </tr> </tbody> </table>							Time t ₀	29-04-2009 – 13:00:32		Slave ID	Responding time and date t	Δt = t – t ₀	S1	29-04-2009 – 13:01:23	0 h 0 min 51 s	S2	29-04-2009 – 14:00:32	1 h 0 min 0 s	S3	29-04-2009 – 14:01:32	1 h 1 min 0 s	S4	30-04-2009 – 03:00:32	14 h 0 min 0 s	S5	30-04-2009 – 12:06:32	23 h 6 min 0 s	Attenuator ID	Attenuation value	Att.1	10 dB	Att.2	0 dB	Att.3	29 dB	Att.4	...	Att.5	...
Time t ₀	29-04-2009 – 13:00:32																																							
Slave ID	Responding time and date t	Δt = t – t ₀																																						
S1	29-04-2009 – 13:01:23	0 h 0 min 51 s																																						
S2	29-04-2009 – 14:00:32	1 h 0 min 0 s																																						
S3	29-04-2009 – 14:01:32	1 h 1 min 0 s																																						
S4	30-04-2009 – 03:00:32	14 h 0 min 0 s																																						
S5	30-04-2009 – 12:06:32	23 h 6 min 0 s																																						
Attenuator ID	Attenuation value																																							
Att.1	10 dB																																							
Att.2	0 dB																																							
Att.3	29 dB																																							
Att.4	...																																							
Att.5	...																																							
History	April 2010	Origin	OPEN METER WP4.1	Inter face	MI1-C11	Applicable	Electricity Meter/ concentrator																																	

Test case ID	3.4.3.4	Type of test	Functional interoperability
Description	Observe performances related to firmware updating.		



Energy Theme; Grant Agreement No 226369

Title: Definition of Test procedures

Version: 0.4

Page: 58 / 110

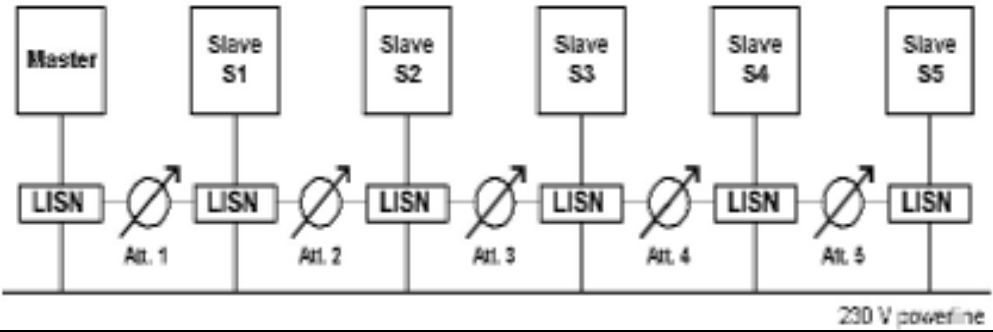
Technology / Prorocol	PLC technologies		
Test Environment	Laboratory X	Field (prototypes in paralell) <input type="checkbox"/>	Field (Substituted Meters) <input type="checkbox"/>
Pre-conditions	<p>Testing configuration :</p> 		
Steps	<p>Description of the test :</p> <p><i>Important note : before performing each test, all products (master and slaves) have to be reset to initial configuration.</i></p> <p>SCENARIO 1 :</p> <ul style="list-style-type: none"> - Set all attenuators to 0 dB, then power on all products. - Wait until the master has registered all slaves. - For each slave perform a firmware update (t = t0). - Wait until the end of transmission. <p>SCENARIO 2 :</p> <ul style="list-style-type: none"> - All attenuators must be set to the same values defined in test [DL 2.1 – SCENARIO 2], then power on all products. - Wait until the master has registered all slaves. - For each slave perform a firmware update (t = t0). - Wait until the end of transmission. 		
Requeriments	OM-CR XX		
Fit criterion	<p>SCENARIO 1 and 2:</p> <p>For each SCENARIO, fill in a table as the example given below :</p>		



Energy Theme; Grant Agreement No 226369

Title: Definition of Test procedures

Version: 0.4

Page: 59 / 110

Time t0	29-04-2009 – 13:00:32		
Slave ID	Responding time and date t	$\Delta t = t - t_0$	
S1	29-04-2009 – 13:01:23	0 h 0 min 51 s	
S2	29-04-2009 – 14:00:32	1 h 0 min 0 s	
S3	29-04-2009 – 14:01:32	1 h 1 min 0 s	
S4	30-04-2009 – 03:00:32	14 h 0 min 0 s	
S5	30-04-2009 – 12:06:32	23 h 6 min 0 s	

During the test, observe the evolution of the data rate (application layer point of view).

In addition, it is necessary to join a table listing the different attenuation values as the example given below :

Attenuator ID	Attenuation value	
Att.1	10 dB	
Att.2	0 dB	
Att.3	29 dB	
Att.4	...	
Att.5	...	

History	April 2010	Origin	OPEN METER WP4.1	Inter face	MI1-C11	Applicable	Electricity Meter/ concentrator
----------------	------------	---------------	------------------	-------------------	---------	-------------------	---------------------------------

Test case ID	3.4.3.5	Type of test	Functional interoperability
Description	Observe the efficiency of alarm functionalities.		
Technology / Prorocol	PLC technologies		
Test Environment	Laboratory X	Field (prototypes in paralell) <input type="checkbox"/>	Field (Substituted Meters) <input type="checkbox"/>
Pre-conditions	<p>Testing configuration :</p> <p style="text-align: right;">230 V powerline</p>		
Steps	<p>Description of the test :</p> <p><i>Important note: before performing each test, all products (master and slaves) have to be reset to initial configuration.</i></p>		



Energy Theme; Grant Agreement No 226369

Title: Definition of Test procedures

Version: 0.4

Page: 60 / 110

SCENARIO 1 :

- Set all attenuators to 0 dB, then power on all products.
- Wait until the master has registered all slaves.
- Each slave sends an alarm to the master ($t = t_0$).
- Wait until the end of transmission.

SCENARIO 2 :

- All attenuators must be set to the same values defined in test [DL 2.1 – SCENARIO 2], then power on all products.
- Wait until the master has registered all slaves.
- Each slave sends an alarm to the master ($t = t_0$).
- Wait until the end of transmission.

SCENARIO 3 :

- All attenuators must be set to the same values defined in test [DL 2.1 – SCENARIO 2], then power on all products ($t = t_0$).
- Wait until the master has registered all slaves.
- Begin the firmware update of slave S5 (downstream).
- Another slave “Si” sends an alarm to the master (upstream).
- Wait until the end of all file transfers.

Requeriments

OM-CR XX

Fit criterion

SCENARIO 1 and 2:

For each SCENARIO, fill in a table as the example given below :

Time t0	29-04-2009 – 13:00:32	
Slave ID	Responding time and date t	$\Delta t = t - t_0$
S1	29-04-2009 – 13:01:23	0 h 0 min 51 s
S2	29-04-2009 – 14:00:32	1 h 0 min 0 s
S3	29-04-2009 – 14:01:32	1 h 1 min 0 s
S4	30-04-2009 – 03:00:32	14 h 0 min 0 s
S5	30-04-2009 – 12:06:32	23 h 6 min 0 s

During the test, observe the evolution of the data rate (application layer point of view).

In addition, it is necessary to join a table listing the different attenuation values as the example given below :

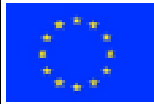

Energy Theme; Grant Agreement No 226369

Title: Definition of Test procedures

Version: 0.4

Page: 61 /
110

		Attenuator ID		Attenuation value			
		Att.1		10 dB			
		Att.2		0 dB			
		Att.3		29 dB			
		Att.4		...			
		Att.5		...			
SCENARIO 3:							
During the test, observe the evolution of downstream and upstream data rates (application layer point of view). Also check the behavior of the master regarding the alarm reception.							
In addition, it is necessary to join a table listing the different attenuation values as the example given below :							
		Attenuator ID		Attenuation value			
		Att.1		10 dB			
		Att.2		0 dB			
		Att.3		29 dB			
		Att.4		...			
		Att.5		...			
History	April 2010	Origin	OPEN METER WP4.1	Inter face	MI1-C11	Applicable	Electricity Meter/ concentrator



4 DLMS Functional Test Cases

4.1 Introduction

This chapter described functional test cases to assure conformity with the Open Meter functional requirements set in WP1. In order to perform these test cases the device shall be DLMS/COSEM compliant.

For these test cases electricity meter is the device under test (DUT). Test cases can be performed via local port or other direct interfaces.

4.2 Presentation of test cases

4.2.1 Provide periodic meter readings (Use case 1)

Next test cases are related to the following Open Meter System Requirements:

OM-SR4: Meter Reading (for Billing)

Test case ID	4.2.1.1		Test type	Functional
Description	<ul style="list-style-type: none"> • Read daily billing profile. Check that at 0 hours, the absolute values of the 6 magnitudes are stored. • The depth of these records must match that of load profiles. The values should not be formed from the incremental values. 			
Technology Protocol	DLMS (over S-FSK PLC, PRIME and GPRS)			
Test Environment [type of environment where the tests are developed]	Laboratory <input checked="" type="checkbox"/>	Field (prototypes in parallel) <input type="checkbox"/>	Field (Substituted Meters) <input type="checkbox"/>	
Pre-conditions	<ul style="list-style-type: none"> • None 			



Energy Theme; Grant Agreement No 226369

Title: Definition of Test procedures

Version: 0.4

Page: 63 / 110

Steps	<ul style="list-style-type: none"> • Synchronize the meter to 14:20 h. • Read energy register and daily billing profile • Inject a load of 30 A (with phase angle = 30°) between 14.25 and 15.25 h • Synchronize the meter to 23.20h • Read energy register and daily billing profile • Inject a load of 30 A (with phase angle = 30°) between 23.25 and 23.55 h • Read energy register and daily billing profile • Synchronize the meter to the next day at 23:58 h. • Wait 3 minutes • Repeat step 2, 10 times <p>Read daily load profile and check that register can contain up to 10 daily registers. Check that the periodic meter reads are available within 5 seconds.</p>						
Requirements	OM-FR2	The electricity meter shall register a meter electricity reading every day at configurable times.				Minimum	
	OM-FR3	The electricity meter shall provide the n most recent daily meter readings for electricity, where n is configurable.				Minimum	
	OM-FR8	The electricity meter shall provide an indication that an error or fraud attempt was registered by the equipment as part of a periodic meter read.				Minimum	
	OM-FR150	The electricity meter shall have periodic meter reads available on SI2-MI2/SI1-CI2 soon after the request was received by the metering installation.				Minimum	
Fit criterion	<ul style="list-style-type: none"> • The result shall contain the 10 most recent daily meter reads E for the given period • The result shall contain the 10 most recent daily meter reads G for the given period • The result shall contain an empty error report as no errors were recorded on the equipment. No error or fraud attempt occurred. 						
History	March 2010	Origin		Inter face	MI2-SI2 / MI1-C11	Applicable	Electricity Meter

Test case ID	4.2.1.2		Test type	Functional
Description	Monthly billing Values Profile			
Technology Protocol	DLMS			
Test Environment [type of environment where the tests are developed]	Laboratory <input checked="" type="checkbox"/>	Field (prototypes in paralell) <input type="checkbox"/>	Field (Substituted Meters) <input type="checkbox"/>	



Energy Theme; Grant Agreement No 226369

Title: Definition of Test procedures

Version: 0.4

Page: 64 / 110

Pre-conditions	None						
Steps	<ul style="list-style-type: none"> • Set end of billing: 01/01/2030. • Set meter time to: 31/12/2029 23:55 • After 10 min, read end of monthly billing period and check that end of billing has values. • Check that all meter readings in the result shall be recorded at 00:00 hours every day. 						
Requirements	OM-FR2	The electricity meter shall register a meter electricity reading every day at configurable times.				Minimum	
	OM-FR4	The electricity meter shall provide the n most recent billign period meter reads for electricity, where n is configurable. The billing period must be configurable.				Minimum	
Fit criterion	<ul style="list-style-type: none"> • The electricity meter shall have available meter readings electricity for each first day of the n most recent billing periods in the past. 						
History	March 2010	Origin		Inter face	MI2-SI2 MI1-C11	Applicable	Electricity meter, Multi-utility meter.

Test case ID	4.2.1.3		Test type	functional
Description	Verification that the end of billing function meet the following requirements: <ul style="list-style-type: none"> . The automatic end of billing supports the highest possible dimension. . The automatic end of billing is successful. . The time synchronization only produces one automatic end of billing (at destination date) 			
Technology / Protocol	DLMS			
Test Environment [type of environment where the tests are developed]	Laboratory <input type="checkbox"/>	Field (prototypes in paralell) <input type="checkbox"/>	Field (Substituted Meters) <input type="checkbox"/>	



Energy Theme; Grant Agreement No 226369

Title: Definition of Test procedures

Version: 0.4

Page: 65 / 110

Pre-conditions	None						
Steps	<ul style="list-style-type: none"> Set end of billing: 01/01/2030. [0-0:13.0.x.255] Set meter time to: 31/12/2029 23:55 [0-0:96.2.12.255] After 10 min, read end of monthly billing period {0-0:98.1.1.255} and check that end of billing has values. Set meter time to 31/12/2000 23:55 [0-0:96.2.12.255] Set end of billing: 01/**/** [0-0:13.0.x.255] Set meter time to 1/1/2002 16:00 [0-0:96.2.12.255] Read end of monthly billing period. {0-0:98.1.1.255} Check that only one end of billing has been produced. Perform a manual billing period end {0-0:10.0.1.255} Check that the closure of the billing period has been produced for the 3 contracts. Standard event log {0-0:98.0.255} event = 66 After 2 minutes ,perform a second manual closing Check that no manual end of billing period has been produced. No event has been produced. Read end of monthly billing period. {0-0:98.1.1.255} After 2 minutes, perform a manual billing period end {0-0:10.0.1.255} Check that the end of the billing period has been produced for the 3 contracts. Standard event log {0-0:99.98.0.255} events = 66 						
Requirements	OM-FR2	The electricity meter shall register a meter electricity reading every day at configurable times.				Minimum	
	OM-FR3	The electricity meter shall provide the n most recent daily meter readings for electricity, where n is configurable.				Minimum	
	OM-FR10	The electricity meter shall issue an error if it has no meter reading from the multi-utility meter available that was registered within the last n hours, where n is configurable.				Minimum	
	OM-FR5	The meter shall register a meter reading gas-water-heat every day at configurable times.				Minimum	
	OM-FR6	The meter shall provide the n most recent daily meter readings for gas-water-heat, where n is configurable				Minimum	
Fit criterion	<ul style="list-style-type: none"> The electricity meter shall have available meter readings electricity for each first day of the n most recent billing periods oin the past. The information provided as periodic meter readings shall at least contin the meter readings electricity for the designated period. 						
History	March 2010	Origin	Open Meter WP4	Interface	MI2-SI2 MI1-CI1	Applicable	Electricity meter



Energy Theme; Grant Agreement No 226369

Title: Definition of Test procedures

Version: 0.4

Page: 66 /
110

Test case ID	4.2.1.4		Test type	Functional			
Description	Retrieve periodic meter reads for an invalid period. The end date of the specified period shall be before the end date of the period.						
Technology / Protocol	DLMS						
Test Environment [type of environment where the tests are developed]	Laboratory <input checked="" type="checkbox"/>	Field (prototypes in paralell) <input type="checkbox"/>	Field (Substituted Meters) <input type="checkbox"/>				
Pre-conditions	None						
Steps	<ul style="list-style-type: none"> The equipment shall issue a logical error indicating an invalid period was specified The response of the meter shall be "object-inavailable" or an array of 0 elements. The error code shall comply with the range specified in the companion standard. 						
Requirements	OM-FR8	The electricity meter shall provide an indication that an error or fraud attempt was registered by the equipment as part of a periodic meter reading.				Minimum	
Fit criterion	<ul style="list-style-type: none"> DLMS: The meter delivers an appropriate error message or an array of 0 elements (no data available) 						
History	March 2010	Origin	Open Meter WP4	Inter face	MI2-SI2 MI1-CI1	Applicable	Electricity meter

4.2.2 Provide on demand meter reads (Use case 2)

Next test cases are related to the following Open Meter System Requeriments:

OM-SR3 System must permit on demand meter reading.

Test case ID	4.2.2.1		Test type	Functional			
Description	Retrieve an actual meter read from an existing E meter						
Technology /	DLMS						



Energy Theme; Grant Agreement No 226369

Title: Definition of Test procedures

Version: 0.4

Page: 67 / 110

Protocol							
Test Environment [type of environment where the tests are developed]	Laboratory <input checked="" type="checkbox"/>	Field (prototypes in paralell) <input type="checkbox"/>			Field (Substituted Meters) <input type="checkbox"/>		
Pre-conditions	None						
Steps	<ul style="list-style-type: none"> • Read energy register object and daily load profile. • Inject a load of 30 A (with phase angle = 30°) during 30 min. • Read energy register object (instantaneous) and check that the values of the energy register have incremented. Check time stamp. • Read daily load profile and check that it has not been affected by the previous action. • Read event log and check that no error has occurred. • Read event log and check that no error has occurred • The actual meter read shall be available on within 5 seconds 						
Requirements	OM-FR9	The electricity meter shall be able to provide the current values of the registers of the electricity and/or gas-water-heat meters on request, without affecting the periodic meter reading process.			Minimum		
	OM-FR151	The electricity meter shall have actual meter reads available on SI2-MI2/SI1-CI2 immediately after the request was received by the metering installation.			Minimum		
Fit criterion	The electricity meter shall provide a valid meter reading.						
History	March 2010	Origin	Open Meter WP4	Inter face	MI2-SI2 MI1-CI1	Applicable	Electricity Meter



Energy Theme; Grant Agreement No 226369

Title: Definition of Test procedures

Version: 0.4

Page: 68 /
110

4.2.3 Provide load profile (use case 4)

OM-SR13: Load profile management

Test case ID	2.1.4.1		Test type	functional
Description	Check the existence of the defined load profiles. Check that in the absence of data, it will be filled with zeros.			
Technology / Protocol	DLMS			
Test Environment [type of environment where the tests are developed]	Laboratory <input checked="" type="checkbox"/>	Field (prototypes in paralell) <input type="checkbox"/>	Field (Substituted Meters) <input type="checkbox"/>	
Pre-conditions	<ul style="list-style-type: none"> None 			
Steps	<ul style="list-style-type: none"> Set integration time of the load profile to 5 min. Check in the event log object that an event has been generated. <ul style="list-style-type: none"> Synchronize at 00:00. Connect a load for 11min. <p>Read load profile</p> <ul style="list-style-type: none"> Synchronize the meter, advancing the date 7 days 15 hours and 35 minutes. Read load profile, initial date: actual date - 8 days. End date: actual date. Read load profile [1-0:99.1.0.255] Connect a load for 11 min. Read load profile [1-0:99.1.0.255] Count the number of registers 2208 read in the 1st profile and check that the value of the first and the last 2 magnitudes are different of zero, The rest of all the magnitudes is 0 and its qualifier is IV. (from the period before advancing the date) 			
Requirements	OM-FR 13	The electricity meter shall register meter readings electricity for a configurable interval.	Minimum	
	OM-FR14	The electricity meter shall provide functionality to retrieve the load profile for a designated period.	Minimum	
Fit criterion	<ul style="list-style-type: none"> The electricity meter shall register a meter reading electricity for configurable intervals. The load profile for the designated period shall at least contain the meter reading electricity. 			



Energy Theme; Grant Agreement No 226369

Title: Definition of Test procedures

Version: 0.4

Page: 69 /
110

History	March 2010	Origin	Open Meter WP4	Interface	MI2-SI2 MI1-CI1	Applicable	Electricity Meter
----------------	------------	---------------	----------------	------------------	--------------------	-------------------	-------------------

4.2.4 Provide power quality information (Use case 6)

Next test cases are related to the following Open Meter System Requirements:

OM-SR19: System must permit power quality management

Test case ID	4.2.4.1		Test type	functional
Description	<p>Test voltage variations – Lower threshold.</p> <p>This test case will test the recording and retrieval by means of DLMS objects of the appropriate event when the voltage drops below the specified threshold. The testcase starts with tests for false recordings.</p> <p>The test is done with a mono-phase and a three-phase meter.</p>			
Technology / Protocol	DLMS			
Test Environment [type of environment where the tests are developed]	Laboratory <input checked="" type="checkbox"/>	Field (prototypes in parallel) <input type="checkbox"/>	Field (Substituted Meters) <input type="checkbox"/>	
Pre-conditions	<ul style="list-style-type: none"> Before retrieving the values the voltage is manipulated in a controlled way in order to generate a number of power sags and swells, 			
Steps	<ul style="list-style-type: none"> Set nominal voltage to 230V for single phase meter and to 400V for three-phase meters. Set the time threshold for lower limit for voltage swells to 180 seconds Set the time threshold for lower limit for voltage sags to 180 seconds Set the threshold for voltage swells to 7% above standard Set threshold for voltage sags to 7% below standard Threshold voltage separation to 50% Set threshold for power limit to 3 minutes Reduce the voltage between R-N to 216 VAC (6%). Wait for 2 minutes and 45 seconds and restore the R-N voltage to its regular value of 230V 			



Energy Theme; Grant Agreement No 226369

Title: Definition of Test procedures

Version: 0.4

Page: 70 /
110

	<ul style="list-style-type: none"> • Read event log and make sure that no Event Codes were recorded. • Reduce the voltage between R-N to 216 VAC (6%). • Wait for 3 minutes and 15 seconds and restore the R-N voltage to its regular value of 230V. • Read event log and make sure that no Event Codes were recorded. • Reduce the R-N voltage to 211 VAC (8%). Check that the voltage indicators are still active for all three phases. • Wait for 2 minutes and 45 seconds and restore the R-N voltage to its regular value of 230V • Read event log and make sure that no Event Codes were recorded. • Reduce the R-N voltage to 211 VAC (8%). • Wait for 3 minutes and 15 seconds. • Read Event Log and make sure that one event code in this group is recorded. • Restore the R-N voltage to its regular value of 230V. • Read Event Log and make sure that one event code in this group is recorded. (finished power quality event) • Check the time stamp of the event log corresponds with the time that the voltage variation ended. • Repeat the steps above for the phases S,T and for the combinations R&S, S&T and RST. 						
Requirements	OM-FR 19	The electricity meter shall provide information on the power over voltages and dips.			Optional		
Fit criterion	<ul style="list-style-type: none"> • The electricity meter shall provide the following: • Equipment identifier for the electricity meter that the information originates from, • Number of power over voltages • Number of power dips. 						
History	March 2010	Origin	Open Meter WP4	Interface	MI2-SI2 MI1-CI1	Applicable	Electricity Meter



Energy Theme; Grant Agreement No 226369

Title: Definition of Test procedures

Version: 0.4

Page: 71 / 110

Test case ID	4.2.4.2		Test type	functional
Description	<p>Test voltage variations – Higher threshold.</p> <p>This test case will test the recording and retrieval by means of DLMS objects of the appropriate event when the voltage drops below the specified threshold.</p> <p>The test is done with both a mono-phase and a three-phase meter.</p>			
Technology / Protocol	DLMS			
Test Environment [type of environment where the tests are developed]	Laboratory <input checked="" type="checkbox"/>	Field (prototypes in paralell) <input type="checkbox"/>	Field (Substituted Meters) <input type="checkbox"/>	
Pre-conditions	<ul style="list-style-type: none"> Before retrieving the values the voltage is manipulated in a controlled way in order to generate a number of power sags and swells, 			
Steps	<ul style="list-style-type: none"> Set nominal voltage to 230V for single phase meter and to 400V for three-phase meters. Set the time threshold for lower limit for voltage swells to 180 seconds Set the time threshold for lower limit for voltage sags to 180 seconds Set the threshold for voltage swells to 7% above standard Set threshold for voltage sags to 7% below standard Threshold voltage separation to 50% Set threshold for power limit to 3 minutes Increase the voltage between R-N to 243 VAC (6%). Check that the voltage indicators are still active for all three phases. Wait for 2 minutes and 45 seconds and restore the R-N voltage to its regular value of 230V Read-out the Event Log and make sure that no Event Codes with code were recorded. Increase the voltage between R-N to 243 VAC (6%). Wait for 3 minutes and 15 seconds and restore the R-N voltage to its regular value of 230V. Read-out the Event log and make sure that no Event Codes were recorded. Increase the R-N voltage to 249 VAC (8%). Wait for 2 minutes and 45 seconds and restore the R-N voltage to its regular value of 230V 			

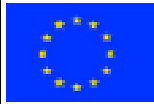
**Energy Theme; Grant Agreement No 226369****Title:** Definition of Test procedures**Version:** 0.4Page: 72 /
110

	<ul style="list-style-type: none"> Read-out the Event Log and make sure that no Event Codes were recorded. Increase the R-N voltage to 249 VAC (8%). Wait for 3 minutes and 15 seconds Read event log and make sure that one event code is recorded Restore the R-N voltage to its regular value of 230V Read-out Event Log and make sure that Finished Power Quality Event was recorded. Check the time-stamp of the event. Repeat the steps above for the phases S,T and for the combinations R&S, S&T and RST. 						
Requirements	OM-FR 19	The electricity meter shall provide information on the power over voltages and dips.				Optional	
Fit criterion	<ul style="list-style-type: none"> The electricity meter shall provide the following: Equipment identifier for the electricity meter that the information originates from, Number of power over voltages Number of power dips. 						
History	March 2010	Origin	Open Meter WP4	Interface	MI2-SI2 MI1-CI1	Applicable	Electricity Meter

4.2.5 Provide interruption information (Use case 7)

Next test cases are related to the following Open Meter System Requirements:

OM-SR10: system must permit interruption information

Test case ID	4.2.5.1		Test type	functional
Description	Retrieve outage information from a E-meter			
Technology / Protocol	DLMS			
Test Environment [type of environment where the tests	Laboratory <input checked="" type="checkbox"/>	Field (prototypes in paralell) <input type="checkbox"/>	Field (Substituted Meters) <input type="checkbox"/>	



Energy Theme; Grant Agreement No 226369

Title: Definition of Test procedures

Version: 0.4

Page: 73 / 110

are developed]			
Pre-conditions	<ul style="list-style-type: none"> - Power supply connected. - Load: No load. - Clock: Current date time. 		
Steps	<ul style="list-style-type: none"> • Reduce the RN voltage to 138VAC (60%). • Wait for 2 minutes and 45 seconds and restore the R-N voltage to its regular value of 230V • Read the Event Log and make sure that <u>no</u> Event Codes (Power Failure, code depending on phase) was recorded. • Reduce the voltage RN to 138 VAC (60%). • Wait for 3 minutes and 15 seconds. • Reset the voltage to nominal valute of 230 VAC • Read-out the Event and make sure that <u>no</u> Event was recorded • Reduce the RN voltage to 92 VAC (40%). • Wait for 2 minutes and 45 seconds and restore the R-N voltage to its regular value of 230V • Read Finished Power Quality Event Log object and make sure that <u>no</u> Event Codes (Power Failure, code depending on phase) was recorded. • Reduce the voltage to 92 VAC (40%) • Wait 3 minutes and 15 seconds. • Restore the voltage level to normal level. • Read the Event Log and make sure that 1 event is logged and check its number. (Power Failure, code depending on phase). • Wait for 5 minutes. • Read the 'Finished Power Quality Event Log' object and make sure that 1 Event Code (Power Failure) was recorded but no voltage variation event. • Make sure that the correct begin of the Power Failure event is logged. • Make sure that the event referring to the correct phase was recorded. • Check that the power quality information shall be available on MI2 or MI1 within 5 seconds. • Repeat the steps above for the phases S,T and for the combinations R&S, S&T and RST. 		
Requirements	OM-FR 19	The electricity meter shall provide information on the power over voltages and dips.	Optional
	OM-FR22	The electricity meter shall provide the number of short power interruptions	Minimum



Energy Theme; Grant Agreement No 226369

Title: Definition of Test procedures

Version: 0.4

Page: 74 / 110

	OM-FR24	In the case of a 3-phase metering installation, a record is also kept in case there is an interruption of one or more of the phase(s)		Minimum			
	OM-FR155	The electricity meter shall have the power quality information available on MI2 or MI1 soon after the request was received by the metering installation		Optional			
Fit criterion	<ul style="list-style-type: none"> The electricity meter shall provide at least the the following information: Equipment identifier for the electricity meter that the information originates from, Number of short electricity interruptions Interruption duration Time stamp for end of the interruption Number of power dips. 						
History	March 2010	Origin	Open Meter WP4	Inter face	MI2-SI2 MI1-CI1	Applicable	Electricity Meter

Test case ID	4.2.5.2		Test type	functional
Description	Retrieve outage information form a e-meter for the n most recent long outages			
Technology / Protocol	DLMS			
Test Environment [type of environment where the tests are developed]	Laboratory <input checked="" type="checkbox"/>	Field (prototypes in paralell) <input type="checkbox"/>	Field (Substituted Meters) <input type="checkbox"/>	
Pre-conditions	<ul style="list-style-type: none"> None 			
Steps	<ul style="list-style-type: none"> Set number of long outages to be provided by the meter. (i.e 10 outages) Force 7 short outages and 11 long outages on the E meter. Read event log. Check that an event report with the 10 most recent log outages is available. Check that the meter provide the number of short outages recorded by the meter since it was installed. Check that the power quality information shall be available on MI2 or MI1 within 5 seconds. 			



Energy Theme; Grant Agreement No 226369

Title: Definition of Test procedures

Version: 0.4

Page: 75 /
110

Requirements	OM-FR23	The electricity meter shall record and provide on request the n most recent long power interruptions, where n is configurable					Minimum
	OM-FR155	The electricity meter shall have the power quality information available on MI2 or MI1 soon after the request was received by the metering installation					Optional
Fit criterion	<ul style="list-style-type: none"> The electricity meter shall provide the 10 (configurable) most recent long power interruptions 						
History	March 2010	Origin	Open Meter WP4	Interface	MI2-SI2 MI1-CI1	Applicable	Electricity Meter

4.2.6 Provide tamper history (tamper detection) (Use case 8)

Next test cases are related to the following Open Meter System Requirements:

OM-SR11: System must permit fraud detection

Test case ID	4.2.6.1		Test type	functional
Description	Check the alarm fraud detection through communication, and the absence of any visible indicator on display to the presence of a high magnetic field. Only applicable to meter able to detect the presence of a magnetic field.			
Technology / Protocol	DLMS			
Test Environment [type of environment where the tests are developed]	Laboratory <input checked="" type="checkbox"/>	Field (prototypes in paralell) <input type="checkbox"/>	Field (Substituted Meters) <input type="checkbox"/>	
Pre-conditions	<ul style="list-style-type: none"> None 			
Steps	<ul style="list-style-type: none"> Apply to the meter a magnetic field higher than TBD Tesla (for at least 5 seconds). Check that the display does not appear in any symbol to indicate fraud detection. Read <u>event Log and check that there is a new event.</u> Read Load profile and check that the intrusion flag bit is set to 1. 			



Energy Theme; Grant Agreement No 226369

Title: Definition of Test procedures

Version: 0.4

Page: 76 / 110

	<ul style="list-style-type: none"> Disconnect the power source that produces the magnetic field. <p>Read <u>Fraud Detection Log and check that there is a new event</u>.</p>						
Requirements	OM-FR25	Metering equipment shall detect physical tamper attempts, including the removal of the terminal cover			Minimum		
	OM-FR27	Metering equipment shall provide a configurable number of detected tamper attempts			Minimum		
Fit criterion	<p>Meter shall register the following information for magnetic intervention:</p> <ul style="list-style-type: none"> Equipment identifier for the meter that detected the magnetic intervention Time stamp of the moment of the intervention. 						
History	March 2010	Origin	Open Meter WP4	Inter face	MI2-SI2 MI1-CI1	Applicable	Electricity Meter

Test case ID	4.2.6.2			Test type	functional
Description	Check the activation of the event of fraud detection due to cover opened via DLMS and the absence any indicator visible in display.				
Technology / Protocol	DLMS				
Test Environment [type of environment where the tests are developed]	Laboratory <input type="checkbox"/>	Field (prototypes in paralell) <input type="checkbox"/>		Field (Substituted Meters) <input type="checkbox"/>	
Pre-conditions	<ul style="list-style-type: none"> None 				
Steps	<ul style="list-style-type: none"> Configure n number of detected tamper attempts. <u>Open the meter cover, break the seal if necessary and check that the display does not show any sign indicating the detection of fraud.</u> Read the Alarm register {0:97.98.a.255,2} and check that the value is intrusion alarm is on.. Read <u>event Log and check that a new event has been generated.</u> Read Load profile status and check that last register is set to invalid. <u>Open and close the meter n+1 times. (wait between each attempt a sufficient time)</u> <u>Read event log and check n events has been generated</u> 				



Energy Theme; Grant Agreement No 226369

Title: Definition of Test procedures

Version: 0.4

Page: 77 /
110

Requirements	OM-FR25	Metering equipment shall detect physical tamper attempts, including the removal of the terminal cover		Minimum			
	OM-FR27	Metering equipment shall provide a configurable number of detected tamper attempts		Minimum			
Fit criterion	<p>E-meter shall register the following information for physical intervention:</p> <ul style="list-style-type: none"> • Equipment identifier for the meter that detected the physical intervention • Time stamp of the moment of the intervention • Type of physical tamper alarm. • The registration of identical tamper events shall be limited to once per 15 minutes. 						
History	March 2010	Origin	Open Meter WP4	Interface	MI2-SI2 MI1-CI1	Applicable	Electricity Meter

4.2.7 (Dis)connect Electricity (Use case 9)

Next test cases are related to the following Open Meter System Requirements:

OM-SR5. System must permit remote disconnection and reconnection

Test case ID	4.2.7.1		Test type	Functional
Description	Disconnect (no time parameter) an E meter and re-connect it. (remotely)			
Technology / Protocol	DLMS			
Test Environment [type of environment where the tests are developed]	Laboratory <input checked="" type="checkbox"/>	Field (prototypes in paralell) <input type="checkbox"/>	Field (Substituted Meters) <input type="checkbox"/>	
Pre-conditions	<ul style="list-style-type: none"> • None The E meter shall be prepared for the test by performing 5 disconnects and connects each;			
Steps	<ul style="list-style-type: none"> • Configure n amounts of (dis)connects to be provided by the meter. 			



Energy Theme; Grant Agreement No 226369

Title: Definition of Test procedures

Version: 0.4

Page: 78 / 110

	<ul style="list-style-type: none"> • Change the state of the switch to 'disconnect' {method 'remote_disconnect'.} • Check in disconnect control log an event has been generated. • Check the state of the switch by visual inspection of the display symbol, which must be DISCONNECTED • Retrieve the outputstate of the switch and check that the switch is DISCONNECTED: Value 1. • Repeat the calling the method 'remote_disconnect'. • Check the state of the switch by visual inspection of the display symbol, which must be DISCONNECTED • Retrieve the output state of the switch and check that the switch is DISCONNECTED: Value 0. • Read the <u>former</u> output state and check that the value is CONNECTED: Value 1. • Change the state of the switch to 'connected' {method 'remote_connect'.} • Check in disconnect control log an event has been generated. • Check the state of the switch by visual inspection of the display symbol, which must be in the connect state. • Retrieve the state of the switch and check that the switch is CONNECTED: Value 1. • Repeat the calling the method 'remote_connect' • Check the state of the switch by visual inspection of the display symbol, which must be in the connect state. • Retrieve the state of the switch and check that the switch is CONNECTED: Value 1. • Read out the <u>former</u> output state and check that the value is DISCONNECTED: Value 0. • Repeat the steps above n+1 time. • Read event log and check that (dis)connect event provides logging information for n (dis)connection. 		
Requirements	OM-FR 28	The electricity meter shall provide functionality to remotely (dis)connect the supply of electrical power on the designated date at the specified time.	Minimum



Energy Theme; Grant Agreement No 226369

Title: Definition of Test procedures

Version: 0.4

Page: 79 / 110

	OM-FR30	The electricity meter shall provide logging information for a configurable amount of (dis)connects					Minimum
	OM-FR31	Electricity meter shall provide logging information for a configurable amount of (dis)connects					Minimum
Fit criterion	<p>The following information for (dis)connects shall be recorded:</p> <ul style="list-style-type: none"> Position of the breaker after the (dis)connect was applied. Time stamp at which the (dis)connect has been applied. 						
History	March 2010	Origin	Open Meter WP4	Inter face	MI2-SI2 MI1-CI1	Applicable	Electricity Meter

Test case ID	4.2.7.2		Test type	functional
Description	Disconnect an E meter and re-connect it. (with time stamp)			
Technology / Protocol	DLMS			
Test Environment [type of environment where the tests are developed]	Laboratory <input checked="" type="checkbox"/>	Field (prototypes in paralell) <input type="checkbox"/>	Field (Substituted Meters) <input type="checkbox"/>	
Pre-conditions	<ul style="list-style-type: none"> None 			
Steps	<ul style="list-style-type: none"> Synchronize the meter to 23:55 on 31-12-2009 Schedule a disconnect of the meter for 00:00 on 01-01-2010 After 5 minutes, check the state of the switch by visual inspection of the display symbol. Retrieve the output state of the and check that the switch is DISCONNECTED: Value: 0. Check manually that you cannot close or move the position of the switch. Check that you cannot reconnect manually by pushing the 			



Energy Theme; Grant Agreement No 226369

Title: Definition of Test procedures

Version: 0.4

Page: 80 / 110

	<p>button. (as would be possible in the state 'ready for reconnect').</p> <ul style="list-style-type: none"> Schedule a connect of the meter for 00:10 on 01-01-2010 Check if the measured values are not changing until 00:10 on 01-01-2010 by reading Active Energy Import twice with a one minute interval. After 5 minutes, check the state of the switch with the and verify that its value is CONNECTED (1). Check if the measured values are changing until 00:100 on 01-01-2010 by reading object Active Energy Import twice with a one minute interval. 						
Requirements	OM-FR 28	The electricity meter shall provide functionality to remotely (dis)connect the supply of electrical power on the designated date at the specified time.				Minimum	
Fit criterion	.						
History	March 2010	Origin	Open Meter WP4	Inter face	MI2-SI2 MI1-CI1	Applicable	Electricity Meter

Test case ID	4.2.7.3		Test type	functional
Description	Disconnect the E meter with time parameter that is in the past.			
Technology / Protocol	DLMS			
Test Environment [type of environment where the tests are developed]	Laboratory <input checked="" type="checkbox"/>	Field (prototypes in paralell) <input type="checkbox"/>	Field (Substituted Meters) <input type="checkbox"/>	
Pre-conditions	<ul style="list-style-type: none"> It is assumed that the fact if a G meter is connected to the E meter does not affect disconnecting and connecting the E meter; 			



Energy Theme; Grant Agreement No 226369

Title: Definition of Test procedures

Version: 0.4

Page: 81 / 110

Steps	<ul style="list-style-type: none"> Load a time parameter to disconnect to be performed at a time that is 5 minutes in the past. Check that the disconnect can not be executed Read event log and check taht an error is generated 						
Requirements	OM-FR 32	The electricity meter shall issue a logical error in case the (dis)connect could not be applied on the indicated date.				Minimum	
Fit criterion	<ul style="list-style-type: none"> Disconnect is to be performed at a time that is 5 minutes in the past, the disconnect can not be executed and an error is generated; The E meter shall be prepared for the test by performing 5 disconnects and connects each; 						
History	March 2010	Origin	Open Meter WP4	Inter face	MI2-SI2 MI1-CI1	Applicable	Electricity Meter

4.2.8 Apply Threshold (electricity) (Use case 10)

Next test cases are related to the following Open Meter System Requirements:

OM-SR6: System must permit power control

Test case ID	4.2.8.1		Test type	Functional
Description	Set the contractual power level for an E meter immediately (i.e. without providing a timestamp)			
Technology / Protocol	DLMS			
Test Environment [type of environment where the tests are developed]	Laboratory <input checked="" type="checkbox"/>	Field (prototypes in paralell) <input type="checkbox"/>	Field (Substituted Meters) <input type="checkbox"/>	
Pre-conditions	<ul style="list-style-type: none"> It is assumed that the fact if a G meter is connected to the E meter does not affect setting and clearing the threshold value in the E meter; The test is executed with no threshold for contractual power applied to the meter; 			



Energy Theme; Grant Agreement No 226369

Title: Definition of Test procedures

Version: 0.4

Page: 82 / 110

Steps	<ul style="list-style-type: none"> Set the contractual power level to a value below I_{max} for the meter E meter shall log the command to set the threshold according to OM-FR 34 The log information shall include generic attributes Apply a load to the meter that exceeds the contractual power level and verify that supply is stopped if the demand exceeds the threshold for more than 30 seconds. After the threshold is exceeded for more than 30 seconds check that the supply is stopped within a second. The E meter shall log the command to disconnect according to OM-FR 30 Verify that supply can be restarted manually by a control on the E meter Check that after a manual reconnect the supply is restored within a second. The E meter shall log the command to connect according to OM-FR 30 Check that the logging for setting the power level shall be available on SI2-MI2/SI1-CI2 with 						
Requirements	OM-FR 33	The electricity meter shall provide functionality to set the values of the threshold remotely as the maximum power of the meter. On receiving the clear command, the thresholds are cleared and the meter relies on the contracted power.				Minimum	
	OM-FR 34	The electricity meter shall log the event that a threshold is set or cleared				minimum	
	OM-FR 35	The electricity meter shall automatically invoke "Test type 9: (Dis)connect E" if the current through the meter exceeds the threshold value				minimum	
	OM-FR 30	The electricity meter shall record logging information for each (dis)connection				Minimum	
	OM-FR 161	The electricity meter shall have the logging information on applying a threshold available on SI2/MI2/SI1-CI2 soon after the request was received by the metering installation.				Optional	
Fit criterion	<ul style="list-style-type: none"> The electricity meter shall disconnect if the net power consumption exceeds the threshold. The threshold is compared with the average net power consumption over a period of n seconds, where n is configurable. 						
History	March 2010	Origin	WP 4.1	Interface	MI2-SI2 MI1-CI1	Applicable	Electricity meter

Test case ID	4.2.8.2	Test type	functional
Description	Clear the contractual power level for an E meter immediately (i.e. without providing a timestamp)		



Energy Theme; Grant Agreement No 226369

Title: Definition of Test procedures

Version: 0.4

Page: 83 / 110

Technology / Protocol	DLMS						
Test Environment [type of environment where the tests are developed]	Laboratory <input checked="" type="checkbox"/>	Field (prototypes in paralell) <input type="checkbox"/>		Field (Substituted Meters) <input type="checkbox"/>			
Pre-conditions	None						
Steps	<ul style="list-style-type: none"> • Clear the contractual power level • The E meter shall log the command to clear the threshold according to OM-FR34. The logging for clearing the power level shall be available on MI2 5 seconds after it was applied • Check that the threshold is cleared on the meter within 5 seconds after the request was received • The log information shall include generic attributes • Apply a load to the meter that exceeds the previously applied contractual power level and verify that supply continues if the demand exceeds the old threshold for more than 30 seconds. • Check that the actual threshold is the maximum (nominal) value of the threshold. 						
Requirements	OM-FR33	The electricity meter shall provide functionality to set the values of the threshold remotely as the maximum power of the meter.			Minimum		
	OM-FR34	The electricity meter shall log the event that a threshold is set or cleared			Minimum		
	OM-FR35	The electricity meter shall automatically invoke "Use case9: Disconnect E" if current through the meter exceeds the threshold value.			Minimum		
	OM-FR160	The electricity meter shall apply the threshold to the supply of electricity within 5 seconds after the request was received.			Optional		
Fit criterion	<ul style="list-style-type: none"> • In case of the clear command, the maximum (nominal) value of the threshold is set. 						
History	March 2010	Origin	Open Meter WP4	Interface	MI2-SI2 MI1-CI1	Applicable	Electricity Meter

**Energy Theme; Grant Agreement No 226369****Title:** Definition of Test procedures**Version:** 0.4Page: 84 /
110

Test case ID	4.2.8.3		Test type	functional
Description	Set the contractual power level for an E meter for 15 minutes in the future			
Technology / Protocol	DLMS			
Test Environment <small>[type of environment where the tests are developed]</small>	Laboratory <input checked="" type="checkbox"/>	Field (prototypes in paralell) <input type="checkbox"/>	Field (Substituted Meters) <input type="checkbox"/>	
Pre-conditions	<ul style="list-style-type: none"> It is assumed that the fact if a G meter is connected to the E meter does not affect setting and clearing the threshold value in the E meter; The test is executed with no threshold for contractual power applied to the meter; 			
Steps	<ul style="list-style-type: none"> Set the contractual power level to a value below I_{max} for the meter for a moment in the future The E meter shall log the command to set the threshold according to OM-FR34 The log information shall include generic attributes Apply a load to the meter that exceeds the contractual power level and verify that supply is stopped only after the threshold is applied and the demand exceeds the threshold for more than 30 seconds After the threshold is exceeded for more than 30 seconds the supply shall be stopped within a second The E meter shall log the command to disconnect according to OM-FR 30 Verify that supply can be restarted manually by a control on the E meter After a manual reconnect the supply shall be restored within a second The E meter shall log the command to connect according to OM-FR 30 The log information shall include generic attributes The threshold shall be applied on the meter within 5 minutes after the indicated time in the request The logging for setting the power level shall be available on MI2 5 seconds after it was applied 			
Requirements	OM-FR33	The electricity meter shall provide functionality to set the values of the threshold remotely as the maximum power of the meter.	Minimum	
	OM-FR34	The electricity meter shall log the event that a threshold is set or cleared	Minimum	
	OM-FR35	The electricity meter shall automatically invoke "Use case9: Disconnect E" if current through the meter exceeds the threshold value.	Minimum	
	OM-FR 30	The electricity meter shall record logging information for each (dis)connection	Minimum	
Fit criterion	<ul style="list-style-type: none"> The meter shall provide functionality to set the values of the threshold remotely as the maximum power of the mter. The command will be performed at the designated date and at the specified time. 			



Energy Theme; Grant Agreement No 226369

Title: Definition of Test procedures

Version: 0.4

Page: 85 / 110

History	March 2010	Origin	Open Meter WP4	Interface	MI2-SI2/SI1/CI-2 MI1-CI1	Applicable	Electricity Meter
----------------	------------	---------------	----------------	------------------	-----------------------------	-------------------	-------------------

Test case ID	4.2.8.4		Test type	functional
Description	Clear the contractual power level for an E meter for a moment 15 minutes in the future			
Technology / Protocol	DLMS			
Test Environment [type of environment where the tests are developed]	Laboratory <input checked="" type="checkbox"/>	Field (prototypes in paralell) <input type="checkbox"/>	Field (Substituted Meters) <input type="checkbox"/>	
Pre-conditions	None			
Steps	<ul style="list-style-type: none"> Apply a load to the meter that exceeds the applied contractual power level and verify that supply is stopped if the demand exceeds the applied threshold for more than 30 seconds Verify that supply can be restarted manually by a control on the E meter After a manual reconnect the supply shall be restored within a second The E meter shall log the command to connect according to OM-FR 30 The log information shall include generic attributes Clear the contractual power level at the indicated time The E meter shall log the command to clear the threshold according to OM-FR34 Apply a load to the meter that exceeds the previously applied contractual power level and verify that supply continues if the demand exceeds the old threshold for more than 30 seconds The threshold shall be cleared on the meter within 5 minutes after the request was received The logging for clearing the power level shall be available on MI2 5 seconds after it was applied 			
Requirements	OM-FR33	The electricity meter shall provide functionality to set the values of the threshold remotely as the maximum power of the meter.	Minimum	
	OM-FR34	The electricity meter shall log the event that a threshold is set or cleared	Minimum	
	OM-FR35	The electricity meter shall automatically invoke "Use case9: Disconnect E" if current through the meter exceeds the threshold value.	Minimum	



Energy Theme; Grant Agreement No 226369

Title: Definition of Test procedures

Version: 0.4

Page: 86 /
110

	OM-FR 30	The electricity meter shall record logging information for each (dis)connection		Minimum			
Fit criterion	<ul style="list-style-type: none"> In case of the clear command, the maximum (nominal) value of the threshold is set. 						
History	March 2010	Origin	Open Meter WP4	Interface	MI2-SI2 MI1-CI1	Applicable	Electricity Meter

4.2.9 Shift tariff times electricity (use cases 14)

Next test cases are related to the following Open Meter System Requirements:

OM-SR2. System must permit remote tariff programming

Test case ID	4.2.9.1		Test type	functional
Description	Set the tariff times for a E meter for the next calendar day for a given meter			
Technology / Protocol	DLMS			
Test Environment [type of environment where the tests are developed]	Laboratory <input checked="" type="checkbox"/>	Field (prototypes in paralell) <input type="checkbox"/>	Field (Substituted Meters) <input type="checkbox"/>	
Pre-conditions	<ul style="list-style-type: none"> It is assumed that a load is applied to the meter that is subject to the current test; During the test the tariff times for the two tariffs are switched (the period that was first assigned to tariff one is during the test assigned to the other tariff) to make it easy to verify if the shift of tariff times actually works correctly			
Steps	<ul style="list-style-type: none"> Retrieve the actual meter readings just before the time the shift of tariff times is to be applied (no change of tariff shall be applied after retrieval of the data and before the shift is applied) Send request to shift the tariff times at the designated day Retrieve the periodic meter reads at the moment of the shift of tariff times Retrieve the actual meter readings just after the time the shift of tariff times is to be applied (no change of tariff shall be applied after before retrieval of the data and after 			



Energy Theme; Grant Agreement No 226369

Title: Definition of Test procedures

Version: 0.4

Page: 87 /
110

	the shift is applied)						
	<ul style="list-style-type: none"> Verify that the load is assigned to the correct tariff before and after applying the shift in tariff times 						
Requirements	OM-FR 47	The electricity meter shall provide functionality to set the tariff shift times at a designated date/time				Minimum	
Fit criterion	<ul style="list-style-type: none"> After the given time on the designated date the tariff shift times are applied and consumption is assigned to the correct tariff according to the tariff shift times. 						
History	March 2010	Origin	Open Meter WP4	Interface	MI2-SI2 MI1-CI1	Applicable	Electricity Meter

4.2.10 Synchronize time E-equipment (Electricity-equipment) (Use case 15)

Next test cases are related to the following Open Meter System Requirements:

OM-SR7: System must permit clock synchronization

Test case ID	4.2.10.1		Test type	functional
Description	Verify if the time synchronization of the E equipment works properly for small deviations (typically < 1 minute) of time.			
Technology / Protocol	DLMS			
Test Environment [type of environment where the tests are developed]	Laboratory <input checked="" type="checkbox"/>	Field (prototypes in paralell) <input type="checkbox"/>	Field (Substituted Meters) <input type="checkbox"/>	
Pre-conditions	It is assumed that the E meter provides a facility to set the time through one of the ports (typically port MI4);			
Steps	<ul style="list-style-type: none"> Set the maximum deviation of the E meter to be 1 minute. Set the time of the E meter to diaviate between 50 and 60 seconds from national standard time Issue a request to synchronize the clock of the equipment Verify that the clock does not deviate more than 1 minute 			



Energy Theme; Grant Agreement No 226369

Title: Definition of Test procedures

Version: 0.4

Page: 88 / 110

Requirements	FR-50	The e-meter shall provide functionality to synchronise its internal clock, and to adjust the maximal deviation that is accepted		Minimum			
Fit criterion	<ul style="list-style-type: none"> The deviation of the clock shall be within the limits of accuracy. The maximum deviation (S) can be set in the electricity meter. 						
History	March 2010	Origin	Open Meter WP4	Interface	MI2-SI2 MI1-CI1	Applicable	Electricity Meter

Test case ID	4.2.10.2		Test type	functional
Description	Verify if the time synchronization of the E equipment works properly			
Technology / Protocol	DLMS			
Test Environment [type of environment where the tests are developed]	Laboratory <input type="checkbox"/>	Field (prototypes in paralell) <input type="checkbox"/>	Field (Substituted Meters) <input type="checkbox"/>	
Pre-conditions	It is assumed that the E meter provides a facility to set the time through one of the ports (typically port MI4);			
Steps	<ul style="list-style-type: none"> Set the maximum deviation of the E meter to be 1 minute. Issue a request to synchronize the clock of the E meter As the time deviates more than the defined maximum a logical error is issued The error shall comply with the description of errors as provided in OM FR-51 The error code shall comply with the range specified in the companion standard for MI2 or MI1 Verify that the clock of the E meter does not deviate more than 1 minute 			
Requirements	OM-FR 50	The e-meter shall provide functionality to synchronise its internal clock, and to adjust the maximal deviation that is accepted		Minimum



Energy Theme; Grant Agreement No 226369

Title: Definition of Test procedures

Version: 0.4

Page: 89 / 110

	OM-FR 51	The electricity meter shall issue a logical error if the time adjustment is larger than the maximum deviation time.				Minimum
Fit criterion	<ul style="list-style-type: none"> The deviation of the clock shall be within the limits of accuracy. If the time deviates more than the defined maximum a logical error is issued that contains, besides the generic attributes for errors, at least the size of time adjustment in seconds. 					
History	March 2010	Origin	OPEN METER WP4	Inter face	MI2-SI2 MI1-CI1	Applicable electricity meter

4.2.11 Firmware upgrade (Business use cases)

Next test cases are related to the following Open Meter System Requirements:

OM-SR8: System must permit remote firmware update

Test case ID	4.2.11.1		Test type	Functional
Description	Verify that the firmware of the E meter can be upgraded remotely with a predefined deployment date. The new version of the firmware shall be deployed in the meter the first calendar day after the test is started.			
Technology / Protocol	DLMS			
Test Environment <small>[type of environment where the tests are developed]</small>	Laboratory <input checked="" type="checkbox"/>	Field (prototypes in paralell) <input type="checkbox"/>	Field (Substituted Meters) <input type="checkbox"/>	
Pre-conditions	<ul style="list-style-type: none"> It is assumed that two determinable versions of the firmware are provided; 			
Steps	<ul style="list-style-type: none"> Retrieve the state of the E meter before the new firmware is uploaded Upload a version firmware to the E meter (the uploaded version shall be different from the version currently applied in the meter). Read event log and check that there is a new event of verification of new firmware . The E meter shall relay the new version of the firmware until the indicated date for deployment Verify that the new firmware is deployed at the indicated time Verify that the state of the equipment is not modified by the deployment of new firmware by comparing the state before and after deployment: <ul style="list-style-type: none"> Check if the load profile is preserved. 			



Energy Theme; Grant Agreement No 226369

Title: Definition of Test procedures

Version: 0.4

Page: 90 / 110

	<ul style="list-style-type: none"> ○ Check if Activity Calendar is preserved. ○ Check if Billing Profile is preserved.. • The E meter shall log the deployment new firmware according to OM-FR63 • Verify that the E meter performed a self-check after the new firmware was deployed by retrieving the results from the self-check 						
Requirements	OM-FR57	The equipment shall provide functionality to upload new firmware to the equipment				Minimum	
	OM-FR58	The equipment shall execute the firmware upgrade at a given date and time. If no date and time are given, the firmware upgrade will be executed immediately.				Minimum	
	OM-FR60	The equipment shall log the event of successful verification of a new version of the firmware				Minimum	
	OM-FR61	Deployment of new firmware shall not result in modification or deletion of any measurement data, configuration parameters or operational parameters in the equipment,				Minimum	
	OM-FR63	The equipment shall log the event of deploying a new version of the firmware				Minimum	
	OM-FR64	The equipment shall provide functionality to invoke a self-check and retrieve the results remotely.				Minimum	
Fit criterion	<ul style="list-style-type: none"> • New version of the firmware shall be stored by the equipment. • The equipment shall delay the firmware upgrade until the designated date and time and then deploy it. • Log information shall contain time stamp at which the new version of the firmware was verified nad deployed. • No operational changes in the functioning of the meter shall occur after deployment of new firmware other than the documented changes for the new firmware. 						
History	March 2010	Origin	Open Meter WP4	Inter face	MI2-SI2 MI1-CI1	Applicable	Electricity Meter/communication hub, Multi-utility meter, concentrator.

Test case ID	4.2.11.2		Test type	Functional
Description	Verify that the firmware of the E meter can be upgraded remotely immediately (without deployment date).			
Technology / Protocol	DLMS			
Test Environment	Laboratory <input checked="" type="checkbox"/>	Field (prototypes in paralell) <input type="checkbox"/>	Field (Substituted Meters) <input type="checkbox"/>	



Energy Theme; Grant Agreement No 226369

Title: Definition of Test procedures

Version: 0.4

Page: 91 / 110

[type of environment where the tests are developed]			
Pre-conditions	<ul style="list-style-type: none"> It is assumed that two determinable versions of the firmware are provided; <p>It is assumed that the fact if a G meter is connected to the E meter does not affect firmware upgrades in the E meter;</p>		
Steps	<ul style="list-style-type: none"> Retrieve the state of the E meter before the new firmware is uploaded Upload a version firmware to the E meter (the uploaded version shall be different from the version currently applied in the meter). The E meter shall log the event of verification of new firmware . Verify that the new firmware is deployed immediately after it was verified Verify that the state of the equipment is not modified by the deployment of new firmware by comparing the state before and after deployment The E meter shall log the deployment new firmware according to OM-FR63 Verify that the E meter performed a self-check after the new firmware was deployed by retrieving the results from the self-check 		
Requirements	OM-FR57	The equipment shall provide functionality to upload new firmware to the equipment	Minimum
	OM-FR58	The equipment shall execute the firmware upgrade at a given date and time. If no date and time are given, the firmware upgrade will be executed immediately.	Minimum
	OM-FR60	The equipment shall log the event of successful verification of a new version of the firmware	Minimum
	OM-FR61	Deployment of new firmware shall not result in modification or deletion of any measurement data, configuration parameters or operational parameters in the equipment,	Minimum
	OM-FR63	The equipment shall log the event of deploying a new version of the firmware	Minimum
	OM-FR64	The equipment shall provide functionality to invoke a self-check and retrieve the results remotely.	Minimum
Fit criterion	<ul style="list-style-type: none"> The new version of the firmware shall be stored by the equipment. The fact that a new version of firmware is available can be verified through the state of the equipment <p>The log information for the event shall at least contain the time stamp at which the new version of the firmware was verified</p> <p>No operational changes in the functioning of the meter shall occur after deployment of new firmware other than the documented changes for the new firmware.</p> <p>The log information for the event shall at least contain the time stamp at</p>		



Energy Theme; Grant Agreement No 226369

Title: Definition of Test procedures

Version: 0.4

Page: 92 / 110

	which the new version of the firmare was deployed.						
History	March 2010	Origin	Open Meter WP4	Inter face	MI2-SI2 MI1-CI1	Applicable	Electricity Meter

Test case ID	4.2.11.3		Test type	Functional
Description	Verify that the E meter generates an error in case the version of the firmware is incomplete and/or inconsistent.			
Technology / Protocol	DLMS			
Test Environment [type of environment where the tests are developed]	Laboratory <input type="checkbox"/>	Field (prototypes in paralell) <input type="checkbox"/>	Field (Substituted Meters) <input type="checkbox"/>	
Pre-conditions	Description of the environment and necessary configuration and set-up to be done before starting the tests.			
Steps	<ul style="list-style-type: none"> • Upload a new version firmware to the E meter (the uploaded version shall be different from the version currently applied in the meter). • The E meter shall log the event of verification of new firmware according to OM-FR60 • The E meter shall issue a logical error indicating that the firmware is incomplete and/or inconsistent • Verify that the uploaded (incomplete, inconsistent) version of the firmware is discarded by the E meter 			
Requirements	OM-FR57	The equipment shall provide functionality to upload new firmware to the equipment	Minimum	
	OM-FR60	The equipment shall log the event of successful verification of a new version of the firmware	Minimum	
	OM-FR59	The equipment shall issue a logical error in case the new firmware is incomplete or inconsistent	Minimum	
Fit criterion	<ul style="list-style-type: none"> • The meter shall issue a logical error in case the new firmware is incomplete or inconsistent. • If a logic error is issued the new firmware shall not be deployed. 			



OPEN meter

Open Public Extended Network metering



Work Package: WP4

Type of document: Deliverable 4.1

Date: 04/06/2010

Energy Theme; Grant Agreement No 226369

Title: Definition of Test procedures

Version: 0.4

Page: 93 /
110

History	March 2010	Origin	Open Meter WP4	Inter face	MI2-SI2 MI1-CI1	Applicable	Electricity Meter
----------------	------------	---------------	----------------	-------------------	--------------------	-------------------	-------------------



Appendix A – Check list of requirements.

The following table represents a check list, summarizing all the requirements covered by the test cases of this documents. The following requirements were selected by the WP4.1 taking into account its testability . The requirements were defined in document D1.1 "Report on the identification and specification of functional, technical, economical and general requirements of advanced multi-metering infrastructure, including security requirements".

ID	Description	Applicability	Category
OM-SR2	System must permit remote tariff programming	System	Minimum
OM-SR3	System must permit on demand meter reading	System	Minimum
OM-SR4	System must permit meter reading for billing	System	Minimum
OM-SR5	System must permit remote disconnection and reconnection	System	Minimum
OM-SR6	System must permit power control	System	Minimum
OM-SR7	System must permit clock synchronization	System	Minimum
OM-SR8	System must permit remote firmware update	System	Minimum
OM-SR10	System must permit interruption information	System	Minimum
OM-SR11	System must permit fraud detection	System	Minimum
OM-SR19	System must permit power quality management	System	Optional
OM-GR19	System must be robust	System	Minimum
OM-FR2	The electricity meter shall register a meter electricity reading every day at configurable times.	Electricity Meter	Minimum
OM-FR3	The electricity meter shall provide the n most recent daily meter readings for electricity, where n is configurable	Electricity Meter	Minimum
OM-FR8	The electricity meter shall provide an indication that an error or fraud attempt was registered by the equipment as part of a periodic meter read	Electricity Meter	Minimum
OM-FR9	The electricity meter shall be able to provide the current values of the registers of the electricity and/or gas-water-heat meters on request, without affecting the periodic meter reading process	Electricity Meter, Multi-utility meter	Minimum
OM-FR10	The electricity meter shall issue an error if it has no meter reading from the multi-utility meter available that was registered within the last n hours, where n is configurable	Electricity Meter, Multi-utility meter	Minimum
OM-FR11	On connecting an end-customer device (on MI5), the electricity meter shall provide	Electricity Meter	Optional



Energy Theme; Grant Agreement No 226369

Title: Definition of Test procedures

Version: 0.4

Page: 95 / 110

	actual meter reads for electricity with a regular interval		
OM-FR13	The electricity meter shall register meter readings electricity for a configurable interval.	Electricity Meter	Minimum
OM-FR15	The electricity meter shall provide on request interval data electricity for the n most recent days, where n is configurable	Electricity Meter	Minimum
OM-FR16	The Gas-Water-Heat meter shall register gas-water-heat meter readings for configurable intervals	Multi-utility Meter	Minimum
OM-FR17	The electricity meter shall provide on request interval data Gas-Water-Heat for the n most recent days, where n is configurable	Electricity Meter, Multi-utility meter	Minimum
OM-FR18	The electricity meter shall provide at regular intervals the actual status of electricity equipment and the last known status for Gas-Water-Heat equipment available in the electricity meter	Electricity Meter	Optional
OM-FR19	The electricity meter shall provide information on the power over voltages and dips	Electricity Meter	Optional
OM-FR20	The electricity meter shall provide the average voltage	Electricity Meter	Optional
OM-FR21	The electricity meter shall provide the number of short (<T) power interruptions. T must be configurable	Electricity Meter	Optional
OM-FR22	The Electricity meter shall provide the long (>T) power interruptions. T must be configurable	Electricity Meter	Minimum
OM-FR23	The electricity meter shall record and provide on request the n most recent long power interruptions, where n is configurable	Electricity Meter	Minimum
OM-FR24	In the case of a 3-phase metering installation, a record is also kept in case there is an interruption on one or more of the phase(s).	Electricity Meter	Minimum
OM-FR25	Metering equipment shall detect physical tamper attempts, including the removal of the terminal cover	Electricity Meter, Multi-utility meter	Minimum
OM-FR26	Metering equipment shall detect tamper attempts with magnetic fields if it is susceptible to these magnetic fields	Electricity Meter, Multi-utility meter	Optional
OM-FR27	Metering equipment shall provide a configurable number of detected tamper attempts	Electricity Meter, Multi-utility meter	Minimum
OM-FR28	The electricity meter shall provide functionality to remotely (dis)connect the supply of electrical power on the designated date at the specified time. If a timestamp (which is an optional parameter) has not been passed as a parameter, the (dis)connect is	Electricity Meter	Minimum



Energy Theme; Grant Agreement No 226369

Title: Definition of Test procedures

Version: 0.4

Page: 96 / 110

OM-FR30	The electricity meter shall record logging information for each (dis)connect	Electricity Meter	Minimum
OM-FR31	The electricity meter shall provide logging information for a configurable amount of (dis)connects	Electricity Meter	Minimum
OM-FR32	The electricity meter shall issue a logical error in case the (dis)connect could not be applied on the indicated date	Electricity Meter	Minimum
OM-FR33	The electricity meter shall provide functionality to set the values of the threshold remotely as the maximum power of the meter. On receiving the clear command, the thresholds are cleared and the meter relies on the contracted power. The command will be p	Electricity Meter	Minimum
OM-FR34	The electricity meter shall log the event that a threshold is set or cleared	Electricity Meter	Minimum
OM-FR35	The electricity meter shall automatically invoke 'Use case 9: (Dis)connect E' if the current through the meter exceeds the threshold value	Electricity Meter	Minimum
OM-FR36	The electricity meter shall provide functionality to let the customer reconnect manually after a disconnect that resulted from exceeding the threshold	Electricity Meter	Minimum
OM-FR42	The E meter shall provide logging information for a reasonable amount of (dis)connects.	Electricity Meter	Optional
OM-FR47	The electricity meter shall provide functionality to set the tariff shift times at a designated date/time.	Electricity Meter	Minimum
OM-FR50	The electricity meter shall provide functionality to synchronise its internal clock, and to adjust the maximal deviation (S) that is accepted compared to the actual time from the central system or the concentrator, where (S) is configurable.	Electricity Meter	Minimum
OM-FR51	The electricity meter shall issue a logical error if the time adjustment is larger than the maximum deviation time (S), where (S) is configurable.	Electricity Meter	Minimum
OM-FR52	If the multi-utility meter has a clock, the electricity meter shall provide functionality to synchronise the time of the multi-utility meter.	Electricity Meter, multi-utility meter	Minimum
OM-FR57	The equipment shall provide functionality to upload new firmware to the equipment.	Electricity Meter/communication hub, multi-utility meter, concentrator	Minimum
OM-FR58	The equipment shall execute the firmware upgrade at a given date and time. If no date and time are given, the firmware upgrade will be executed immediately.	Electricity Meter/communication hub, multi-utility meter, concentrator	Minimum



Energy Theme; Grant Agreement No 226369

Title: Definition of Test procedures

Version: 0.4

Page: 97 /
110

OM-FR59	The equipment shall issue a logical error in case the new firmware is incomplete or inconsistent.	Electricity Meter/communication hub, multi-utility meter, concentrator	Minimum
OM-FR60	The equipment shall log the event of successful verification of a new version of the firmware.	Electricity Meter/communication hub, multi-utility meter, concentrator	Minimum
OM-FR61	Deployment of new firmware shall not result in modification or deletion of any measurement data, configuration parameters or operational parameters in the equipment.	Electricity Meter/communication hub, multi-utility meter, concentrator	Minimum
OM-FR63	The equipment shall log the event of deploying a new version of the firmware.	Electricity Meter/communication hub, multi-utility meter, concentrator	Minimum
OM-FR64	The equipment shall provide functionality to invoke a self-check and retrieve the results remotely	Electricity Meter/communication hub, multi-utility meter, concentrator	Minimum
OM-FR65	The equipment shall discard the new version of the firmware in case it is incomplete or inconsistent.	Electricity Meter/communication hub, multi-utility meter, concentrator	Minimum
OM-FR68	The electricity meter shall provide functionality to automatically adjust to daylight savings time and back.	Electricity Meter, multi-utility meter	Minimum
OM-FR75	The electricity meter should provide functionality to set location information in the meter after the meter is physically installed but before the meter is deployed.	Electricity Meter	Optional
OM-FR77	The meter shall provide functionality to set the disconnectable flag at the manufacturing site and after the meter is physically installed.	Electricity Meter	Minimum
OM-FR78	The electricity meter shall provide functionality to invoke 'Use case: Adjust equipment' remotely or locally.	Electricity Meter	Minimum
OM-FR79	The electricity meter shall provide functionality to invoke 'Use case: Perform self-check electricity meter' and retrieve the results remotely (MI1 or MI2) or locally (MI3 or display).	Electricity Meter	Minimum
OM-FR80	After the electricity meter is physically installed and functions correctly, communication shall be established automatically.	Electricity Meter	Minimum
OM-FR150	The electricity meter shall have periodic meter reads available on SI2-MI2/SI1-CI2 soon after the request was received by the metering installation.	Electricity Meter	Minimum
OM-	The electricity meter shall have actual meter	Electricity Meter	Minimum



Energy Theme; Grant Agreement No 226369

Title: Definition of Test procedures

Version: 0.4

Page: 98 /
110

FR151	reads available on SI2-MI2/SI1-CI2 immediately after the request was received by the metering installation.		
OM-FR155	The electricity meter shall have the power quality information available on MI2 or MI1 soon after the request was received by the metering installation.	Electricity Meter	Optional
OM-FR160	The electricity meter shall apply the threshold to the supply of electricity within 5 seconds after the request was received.	Electricity Meter	Optional
OM-FR161	The electricity meter shall have the logging information on applying a threshold available on SI2-MI2/SI1-CI2 soon after the request was received by the metering installation.	Electricity Meter	Optional
OM-CR3	When PLC is used, the minimum speed must be 2.4 kbps for a reliable communication	Communications	Minimum
OM-CR4	A reliable faster PLC interface should be possible.	Communications	Optional
OM-CR6	Automatic meter detection must be supported	Communications	Minimum
OM-CR7	A phase detection mechanism must be supported	Communications	Minimum
OM-CR8	Adaption to topology changes must be supported	Communications	Minimum
OM-CR11	In case of having several PLC signals, due to crosstalk, it should not make communication impossible	Communications	Minimum
OM-CR12	New PLC technologies defined in this project and PLC technologies compliant to standards used within this project should permit coexistence in the same network	Communications	Minimum



Appendix B.- DLMS/COSEM Conformance testing

Introduction

The DLMS User Association operates a conformance testing scheme, to verify that the DLMS/COSEM specification is correctly implemented in metering equipment.

The primary purpose of conformance testing is to increase the probability that different implementations are interoperable. While conformance testing is a necessary condition, it is not on its own a sufficient condition to guarantee interoperability. Even if two implementations conform to the same protocol specification, they may fail to be fully interoperable.

What conformance testing does do is give confidence that an implementation has the required capabilities and that its behavior conforms consistently in representative instances of communication.

The DLMS/COSEM conformance testing process

The DLMS/COSEM conformance testing process comprises the following:

- the conformance test plans;
- the Conformance Test Tool (CTT);
- the conformance assessment process;
- the certification process;
- the quality program.

It is illustrated in Figure 3.

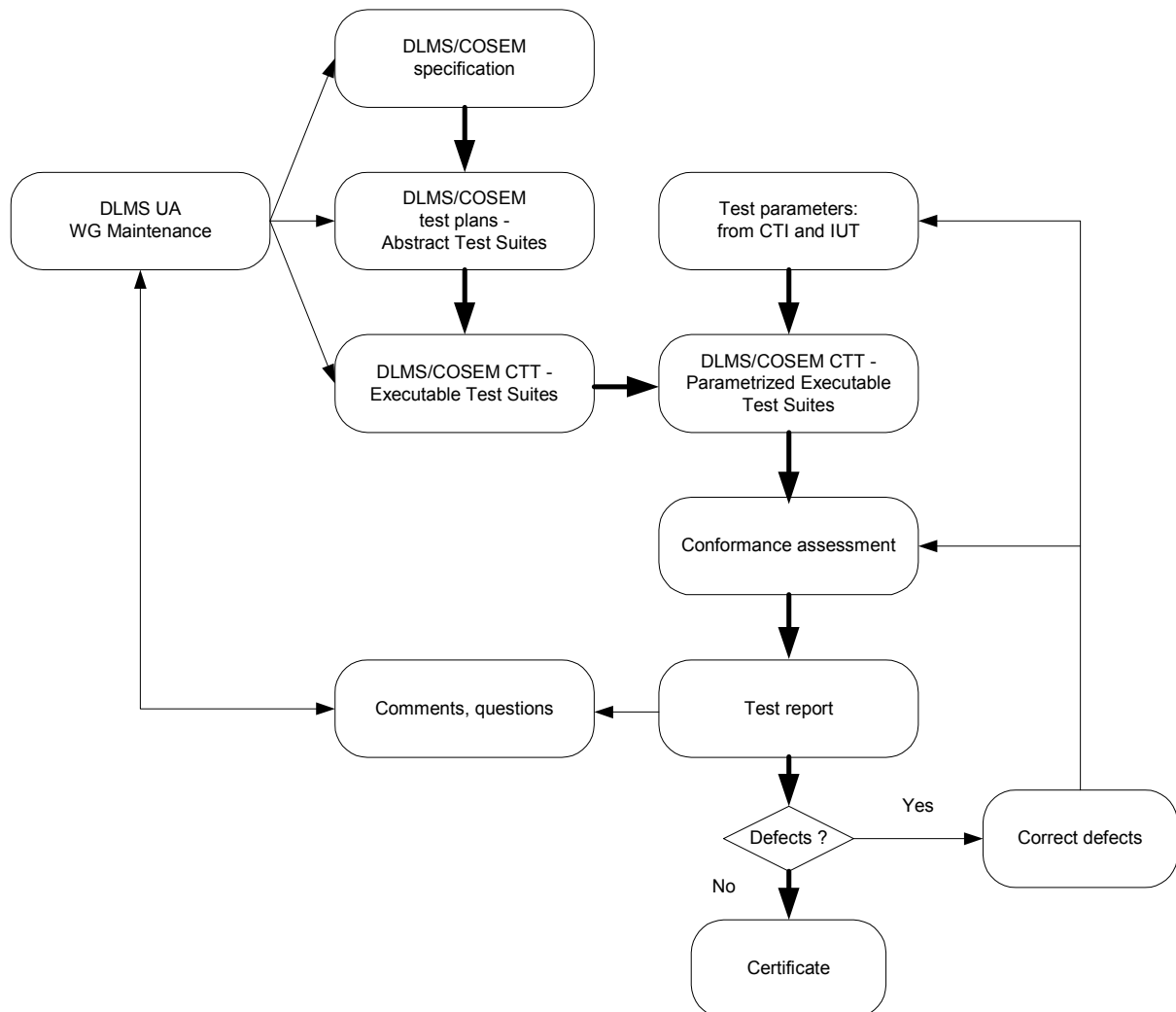

Figure 3 – DLMS/COSEM conformance testing process

The conformance test plans - Abstract Test Suites (ATS) - describe, at the level of abstraction, the test to be performed.

The Conformance Test Tool (CTT) implements the Abstract Test Suites in the form of Executable Test Suites.

The conformance assessment process consists of the phases of preparation for testing, test operations and conformance test report production.

The certification process consists of examining conformance test reports and publication of Certificates.

The quality program includes handling comments and questions and initiating the maintenance of the specification, the conformance test plans and/ or the CTT as appropriate.



Main features of DLMS/COSEM conformance testing

The main features of the DLMS/COSEM conformance testing process are summarized below:

- it covers servers implementing the COSEM interface object model and one or more DLMS based communication profiles;
- it is limited to the server's functionality as presented at the communication interface. Other functions of the server are out of the Scope of conformance testing;
- the conformance test plans and the CTT are provided by the DLMS UA. They are available to all members of the DLMS UA;
- the CTT can be used for self-testing and third party testing, at the conditions published at the homepage of the DLMS UA, at www.dlms.com;
- the certification process can be initiated by any member of the DLMS UA;
- to obtain a Certificate, the manufacturer of the IUT shall possess a registered three-letter manufacturer ID; see <http://dlms.com/flag/index.htm>;
- the CTT automatically generates the documents necessary for the Certification;
- the Certification is issued by the DLMS UA;
- the DLMS UA operates a Quality program to maintain the test plans and the CTT.

Scope of testing

The conformance test plans cover:

- the COSEM Interface objects;
- the COSEM Application layer;
- the data link layer using HDLC protocol.

All other protocol layers are implicitly tested.

Device testing

A single device is conformance tested against a single test source.

For the purposes of testing, the IUT is considered as a black box. The test consists of sending messages to the IUT and observing the responses.

As access to layer boundaries is not available, the interface object model and the protocol stack are tested in combination. Therefore, the following assumptions are made:

- for testing the data link layer using HDLC protocol, it is assumed that the physical layer works correctly;
- for testing the COSEM Application layer, it is assumed that the supporting layers work correctly;
- for testing the COSEM Interface object model, it is assumed that the protocol stack works correctly.

Structure of the conformance test plans

Each test plan comprises an abstract test suite (ATS).

Test suites have a hierarchical structure (see Figure 4) in which an important level is the test case.



Each test case has a specified test purpose, such as that of verifying that the IUT has a certain required capability (e.g. the ability to support certain packet sizes) or exhibit a certain required behaviour (e.g. behave as required when a particular event occurs in a particular state).

Within a test suite, nested test groups are used to provide a logical ordering of the test cases.

Associated with each test group is a test group objective.

Test cases may be modularised by using named subdivisions called subtests.

Test events are indivisible units of specification within a test step (e.g. the transfer of a single PDU to or from the IUT).

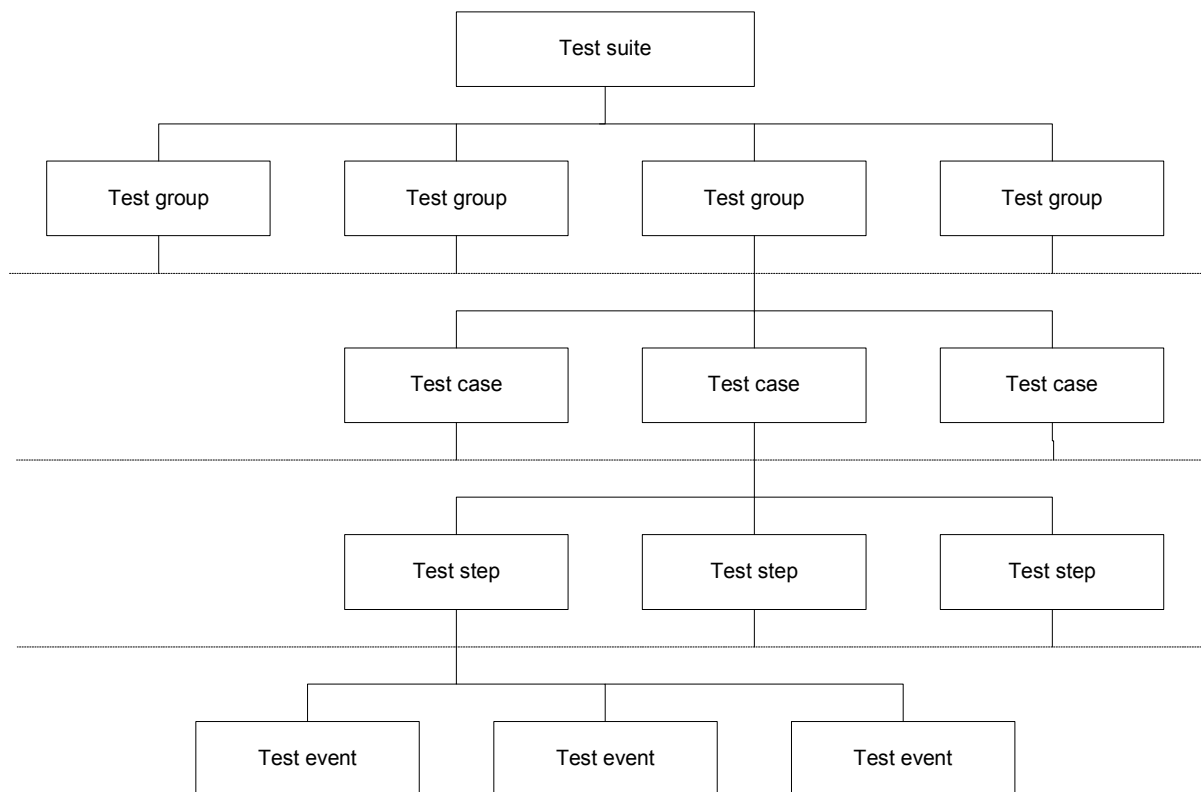

Figure 4 – Test suite structure

Test suites include test cases falling in the following categories (the list is not exhaustive):

- capability tests;
- behaviour tests of valid behaviour (positive tests);
- behaviour tests of syntactically invalid or inopportune behaviour (negative tests);
- test focusing on PDUs sent to and received from the IUT;
- test related to each protocol phase;
- timing;
- PDU encoding variations;
- variations in values of individual parameters and/or combination of parameters.



Energy Theme; Grant Agreement No 226369

Title: Definition of Test procedures

Version: 0.4

Page: 103 /
110

Abstract test cases

An abstract test case is derived from a test purpose and from the relevant specifications. An abstract test case:

- has a *Test case* name, used as a reference and relating the test case to the test group and the test suite;
- gives the *References* pointing to the relevant clauses of the Blue Book [1] and/or the Green Book [2], constituting the base specification, the test case is related to and derived from;
- specifies the *Test purpose*;
- specifies the expected behaviour of the IUT; this comprises the *Expected result*;
- specifies, if the initial testing state required by the test body is not the desired starting stable state of the test case, the sequence of events to put the IUT to the initial testing state for the test body; this test sequence comprises the *Preamble*;
- specifies the sequences of foreseen test events necessary in order to achieve the test purpose. These sequences comprise the *Test body*. It may consist of one or more subtests;
- specifies, if the test body can end without the IUT being returned to the desired stable testing state, the sequence of events to return the IUT to the desired stable testing state; this test sequence comprises the *Postamble*;
- specifies the verdict to be assigned to each foreseen test outcome.

The abstract test cases are formatted using the template shown in Table 1.

Table 1 – Template for test cases

Test case	
References	
Test purpose	
Expected result	
Preamble	
Test body	
Postamble	
Comments	

Test outcomes and verdicts

The test outcome is the series of events, which occurred during execution of a test case.

A foreseen test outcome is one, which has been defined by the abstract test case i.e. the events which occurred during execution of the test case matched a sequence of test events defined in the abstract test case. A foreseen test outcome always results in the assignment of a test verdict to the test case.

The test verdict will be PASSED, FAILED or INCONCLUSIVE:

PASSED – Means that the observed test outcome gives evidence of conformance to the conformance requirement(s) on which the test purpose of the test case is focused, and is valid with respect to the relevant specification(s);

FAILED – Means that the observed test outcome either demonstrates non-conformance with respect to (at least one of) the conformance requirement(s) on which the test



Energy Theme; Grant Agreement No 226369

Title: Definition of Test procedures

Version: 0.4

Page: 104 /
110

purpose of the test case is focused, or contains at least one invalid test event, with respect to the relevant specification(s);

INCONCLUSIVE – Means that the observed test outcome is such that neither a pass nor a fail verdict can be given.

An unforeseen test outcome is one, which has not been identified by the abstract test case, i.e. the events, which occurred during execution of the test case did not match any sequence of test events defined in the abstract test case. An unforeseen test outcome always results in the recording of a test case error or an abnormal test case termination for the test case.

A test case error is recorded if an error is detected either in the abstract test case itself, (i.e. an abstract test case error) or in its realization, (i.e. an executable test case error).

An abnormal test case termination is recorded if the execution of the test case is prematurely terminated by the test system for reasons other than test case error.

The results of executing the relevant individual test cases will be recorded in the conformance test report.

Conformance test plan for the Data link layer using HDLC protocol

The structure of the Conformance test plan for the Data link layer using HDLC protocol is shown in Figure 5.

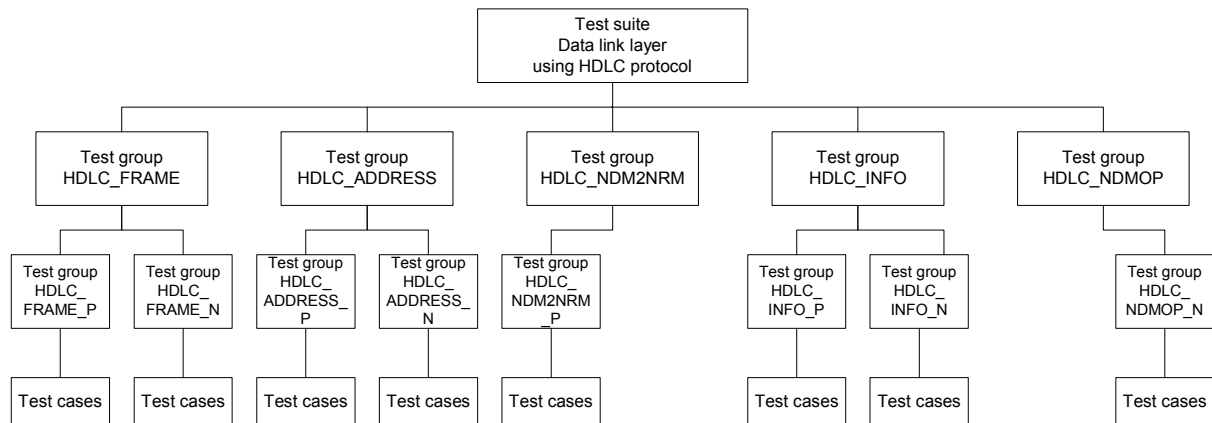

Figure 5 – Structure of the Conformance test plan for the Data link layer using HDLC protocol

Conformance test plan for the COSEM application layer

The structure of the Conformance test plan for the Data link layer using HDLC protocol is shown in Figure 6.

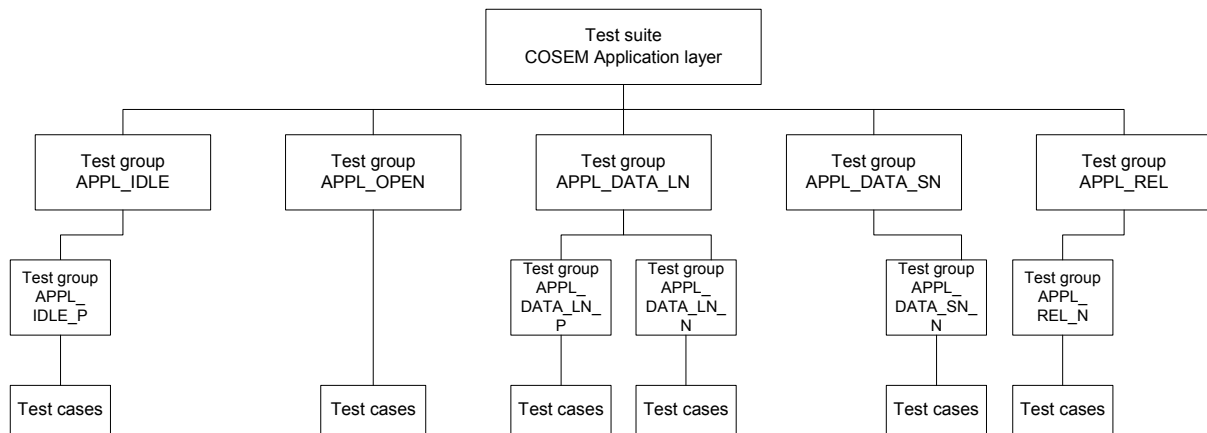
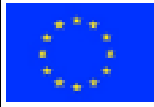

Figure 6 – Structure of the conformance test plan for the COSEM Application layer

Conformance test plan for the COSEM interface objects

The structure of the COSEM interface classes is shown in Figure 7.

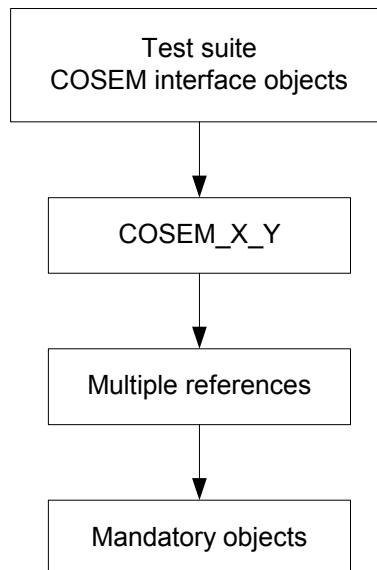

Figure 7 – Structure of the conformance test plan for the COSEM interface objects

The test strategy follows the model of DLMS/COSEM servers:

- the IUT is a physical device, containing one or more logical devices;
- a logical device may support one or more application associations;
- the IUT may support one or more communication profiles. These can be tested in separate test campaigns;
- the IUT may support one or more application contexts. These can be tested in separate test campaigns.

The general algorithm of testing COSEM interface objects is the following:



Energy Theme; Grant Agreement No 226369

Title: Definition of Test procedures

Version: 0.4

Page: 106 /
110

for each logical device:

- for each application association:
 - build the AA and read the object_list;
 - sort the list according to class_id and version;
 - for each object, execute the corresponding COSEM_X_Y attribute test;
 - perform Multiple references test;
 - check presence and report value of mandatory elements:
 - attributes of the Current Association object, including a textual report of the object list;
 - logical device name.

The information for testing is obtained from the IUT itself and from the Conformance Test Information (CTI) file.

The DLMS/COSEM conformance test tool

The DLMS/COSEM conformance test tool (CTT) is an implementation of the abstract test suites (ATS) in the form of executable test suites (ETS). It can perform the following:

the selection of test cases;
the parametrization of the test cases;
the execution of test cases; and
the production of the Conformance test report and a Conformance log.

The CTT therefore is a Means of testing (MOT) as defined in [6] 3.2.32.

The conformance test report, the conformance log and the line traffic

During a test campaign, the CTT automatically generates three documents:

the conformance test report;
the conformance log; and
the line traffic.

These documents record the result of test campaigns and they are used for analysing the results and for the production of the Certificate.

The conformance test report identifies the test environment and includes the result of the testing.

The purpose of the conformance test log and the line traffic is to record all test events and test outcomes, including any exceptions, and to allow verifying the assignment of verdicts.

The CTT can be enhanced with a log module. This allows logging the HDLC frames, the APDUs or both and presents them in a decoded, human readable form.



The conformance assessment process

The conformance assessment process is the complete process of accomplishing all conformance testing activities necessary to enable the conformance of the IUT to be assessed.

It may be performed by an identifiable part of a manufacturer's organization (self-testing), a user or an independent test house (third party testing).

An overview of the conformance assessment process is given in Figure 8

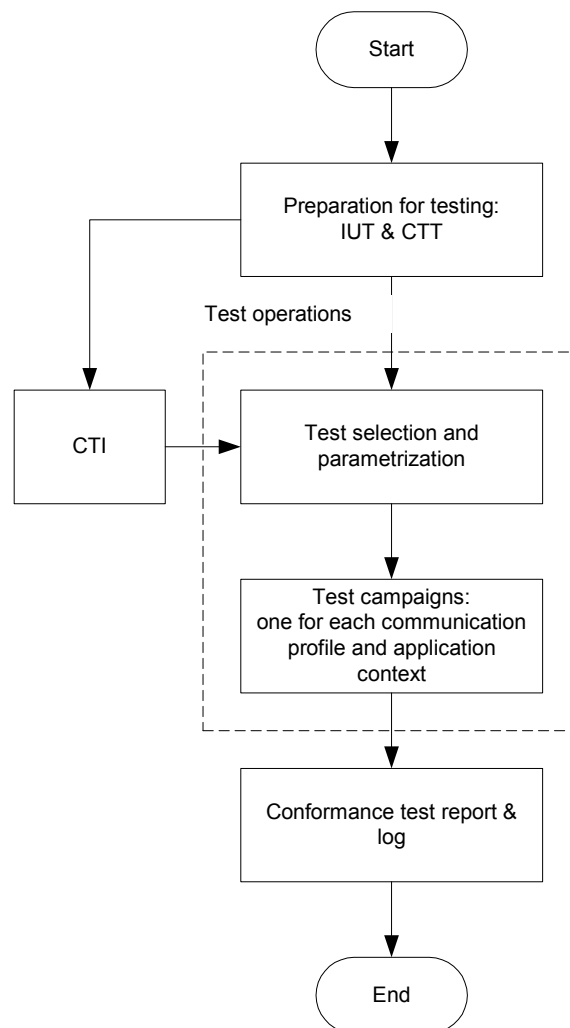

Figure 8 – Conformance assessment process overview

The Certification

Certification reports are published at www.dlms.com

By June 2010, more 140 Certificates has been issued.



The template is shown in Figure 9.



DLMS User Association

Pre-de-la-Fontaine 19 Tel: +41 22 980 980 0
CH-1217 Meyrin-Geneva Fax: +41 22 980 980 9
Switzerland dlms@dlms.com

Certification No.

This is to certify that the metering equipment identified as:

Type:

Mgmt. LDN:

manufactured by:

has successfully passed the DLMS/COSEM Conformance test, under the following conditions:

- CTT version: CTT 2.0
- Licensed to:
- COSEM object definitions file version:

Test performed	Communication profile	Operating mode	Application context	Date and time	Digital signature of the test report
Test 1					
Test 2					
Test 3					

The authenticity of the test report(s) has been verified by the DLMS User Association and the metering equipment identified above is listed on its web site at: <http://www.dlms.com>.

With this, the manufacturer is entitled to display the DLMS/COSEM Compliant mark – shown below – on its product duly identified and on its product literature.



The test reports are filed by the DLMS UA. Copies are available from the manufacturer.

This Certificate is only valid for the functions successfully tested. The test has been executed on one specimen of the product, as identified by the Management Logical Device Name reported. Results may not be applicable for other test specimens.

Date: Geneva, the

Paul Fuchs

General Secretary

Figure 9 – DLMS/COSEM Conformance Certification template

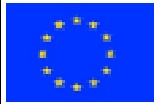

OPEN meter

Open Public Extended Network metering



Work Package: WP4

Type of document: Deliverable 4.1

Date: 04/06/2010

Energy Theme; Grant Agreement No 226369

Title: Definition of Test procedures

Version: 0.4

Page: 109 /
110



OPEN meter

Open Public Extended Network metering



Work Package: WP4

Type of document: Deliverable 4.1

Date: 04/06/2010

Energy Theme; Grant Agreement No 226369

Title: Definition of Test procedures

Version: 0.4

Page: 110 /
110

Copyright

“Copyright and Reprint Permissions. You may freely reproduce all or part of this paper for non-commercial purposes, provided that the following conditions are fulfilled: (i) to cite the authors, as the copyright owners (ii) to cite the OPEN meter Project and mention that the European Commission co-finances it, by means of including this statement “OPEN meter. Energy Project No 226369. Funded by EC” and (iii) not to alter the information.”